



# CAST-RESIN INSULATED BUSWAY SYSTEMS

## LOW VOLTAGE

COMPRESSED DIGITAL SIGNAL

```
blue_target=1000  
[Sensor Settings]  
Input_Polarity=Negative  
CDS=On  
Sensor_Type=EvenOdd  
Optical_Resolution=600  
Line_Separation=-8  
Line_Rate_1/3_Difference=100  
Max_Move_Speed=0.8  
Start_of_Calibration=0
```

```
Calibration_Strip_Height=50  
start_of_scan=330  
Steps_To_Accelerate_Minor=100  
Image_Pixel_Width=5100  
Scan_Line_Length=11.70  
Line_Type=No  
Minimum_Static_Gain=1  
TR_Stepper_Correction=1  
Distorted_Dummy_Lines=60
```

```
[Sensor Settings]  
Input_Polarity=Negative  
CDS=On  
Sensor_Type=EvenOdd  
Optical_Resolution=600  
Line_Separation=-8  
Line_Rate_1/3_Difference=100
```

bbs\_config.pl

ZBBS

Arial

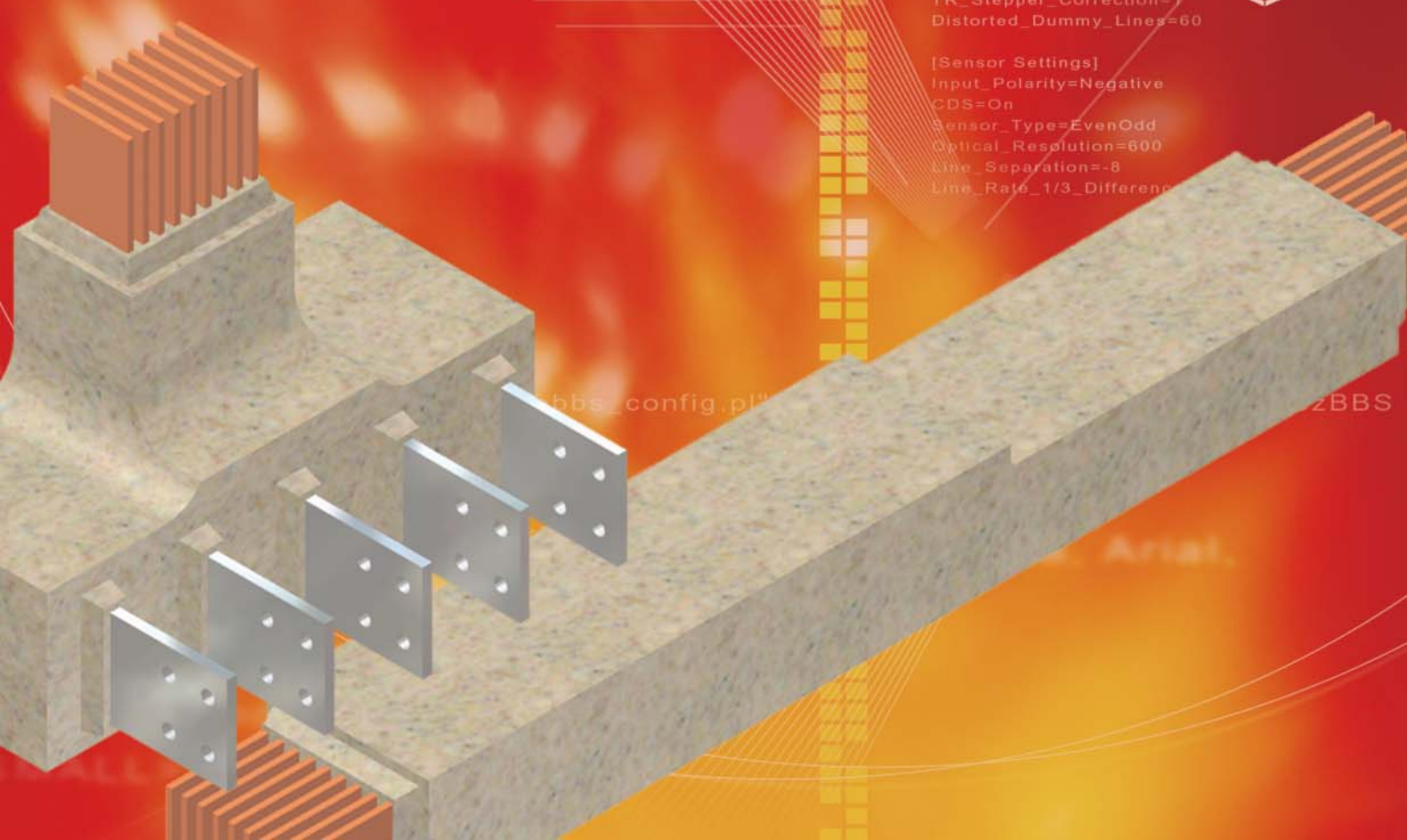



# Content

- ▶ **Content**.....P 1-1
- ▶ **Foreword**.....P 1-2
- ▶ **Excellence**.....P 1-3
- ▶ **Product Feature**.....P 1-4
- ▶ **Product Certification**.....P 1-5
- ▶ **Electrical Characteristics of Low Voltage Busway**.....P 1-8
- ▶ **Product Specifications**.....P 1-9
- ▶ **Selection of Standard Parts (Low Voltage Series)**.....P 1-15
- ▶ **Product Installation**.....P 1-18
- ▶ **Assembly Diagrams of Low Voltage Busway Junction**.....P 1-19
- ▶ **Low Voltage Busway Horizontal Hanger Standard**.....P 1-20
- ▶ **Low Voltage Busway Vertical Hanger Standard**.....P 1-21
- ▶ **Dimensions of Standard Terminal Elements for Low Voltage Busway**.....P 1-22
- ▶ **Dimensions of Standard Terminal Elements Copper Plate for Low Voltage Busway**.....P 1-24
- ▶ **Opening Requirement of Standard Terminal Elements and Switchgear for Low Voltage Busway**...P 1-25
- ▶ **Low Voltage Busway Terminal Element and Switchgear Standard Guideline**.....P 1-26
- ▶ **Low Voltage Busway Terminal Element and Generator Connection Standard**.....P 1-27
- ▶ **Plug-in Unit**.....P 1-28
- ▶ **Product Design Theory**.....P 1-29
- ▶ **Low Voltage Busway Routine Test Items**.....P 1-30
- ▶ **Projects Reference List**.....P 1-31







# Foreword

TAIAN-ETACOM TECHNOLOGY was formally called TAIAN Electric Co. Ltd. (Teco Group). With the drastic increase in the requirement of safety and stability for power distribution in the domestic hitech industry, commercial building, and public engineering. However the traditional power cable and metal-enclosure busway can no longer fulfill the requirement stated above.

Therefore, the team of Teco Group imported the world leading BUSWAY technology manufacturer, ETACOM betobar-r of Belgium, for the Taiwan market in 1988. The product has the excellent features of electrical characteristics and mechanical strength, fire and water proof, anti-corrosion, smaller size, and maintenance free. All these features are better than the traditional metal-enclosure busway. Therefore the cast resin busway are popularly used in the industry field.



Due to the delivery period of import goods are always too long to fulfill the needs of customers. Therefore, TAIAN and ETACOM were joined as TAIAN-ETACOM in October 1999. Moreover, TAIAN-ETACOM introduced the producing technology of ETACOM betobar-r busway to provide the high quality, short delivery period and completely customer service.

We commit to provide the best completely services to our customers. We hope our customers keep giving us their support and encouragement. Your comment will be highly appreciated.





1. Low voltage products meet the standard of IEC 60439-1 、 IEC 60439-2 、 IEC 61439 、 CNS 14286.
2. Compact, easy to install, no emission of toxic gas.
3. The purity of conductor is 99.9% for copper with conductivity above 98% IACS.
4. Voltage drop low 、 high short-circuit current withstand, carried out overload 20% for 2 hours.
5. Degree of protection tested in accordance with IEC 60529, IP68. Mechanical Impacts IK10.
6. Fire-proof property:  
At 750°C for 3 hours tested in accordance with IEC 60331-21.  
At 840°C for 30 minutes tested in accordance with CNS 14286.
7. Fire-proof wall partitions meet S120 in accordance with IEC 60332-3, and meet NBN 713-020 add3.
8. Fire-proof partitions in the piping in accordance with IEC 60332-3.
9. Anti-explosion certification meets EN 50028 no. EEx m II .
10. Mixing excellent material such as non-organic volcanic rock with small amount of resin made of busway. With excellent insulation and heat dissipation properties.
11. Low EMC.
12. Insulation level of class B 130°C .
13. Products have shown excellent results for at least 40 years, and passed aging test with safety operation over 50 years .
14. Maintenance free.
15. CE and UL certified.

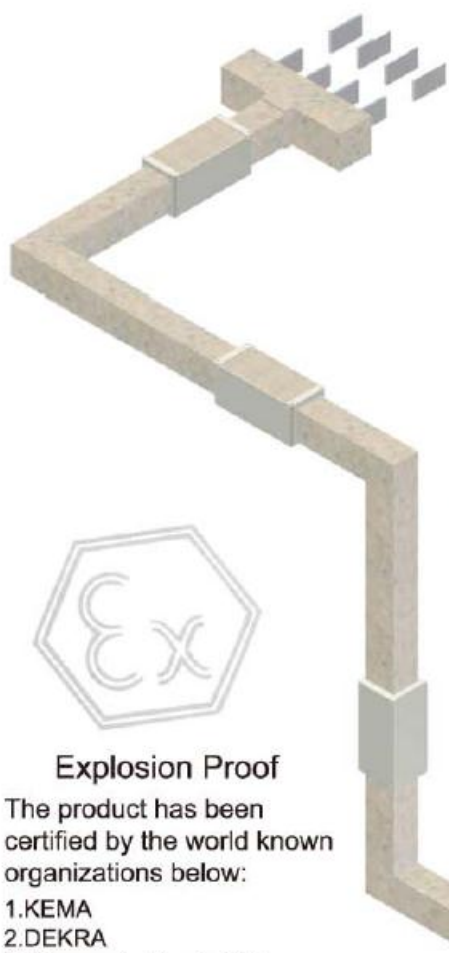

**Explosion Proof**

The product has been certified by the world known organizations below:

- 1.KEMA
- 2.DEKRA
- 3.3C organization in China.
- 4.Taiwan Electric Research & Testing Center.
- 5.Fireproof Lab. of National Cheng Kung University.

**EMC**  
Electromagnetic compatibility

**IK10**  
Mechanical Impacts

**E30**  
Fire Proof

**CNS 14286**  
Withstand Fire Test

**IP68**  
Degree of protection

**S120**  
Fire Partitions



# Product Feature

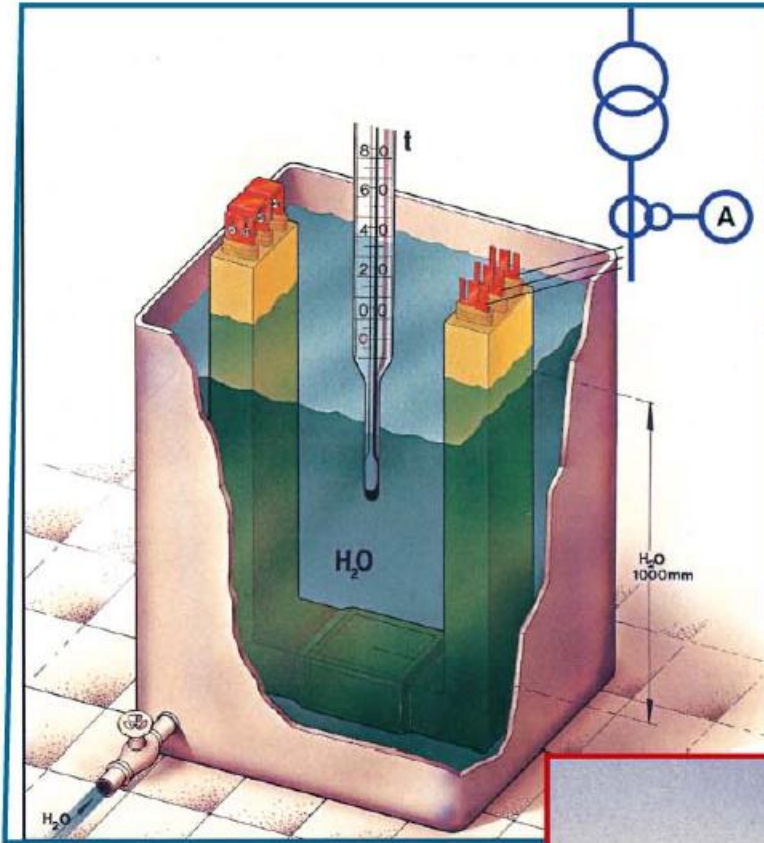

## Waterproof

The water-proof tested (junction included) in accordance with IEC 60529 IP68.

## Fireproof



The fire-proof at 750°C for 3 hours tested in accordance with IEC 60331-21.  
At 840°C for 30 minutes tested in accordance with CNS 14286 and JIS 8364.  
At 950°C for 3 hours tested in accordance with BS 6387.

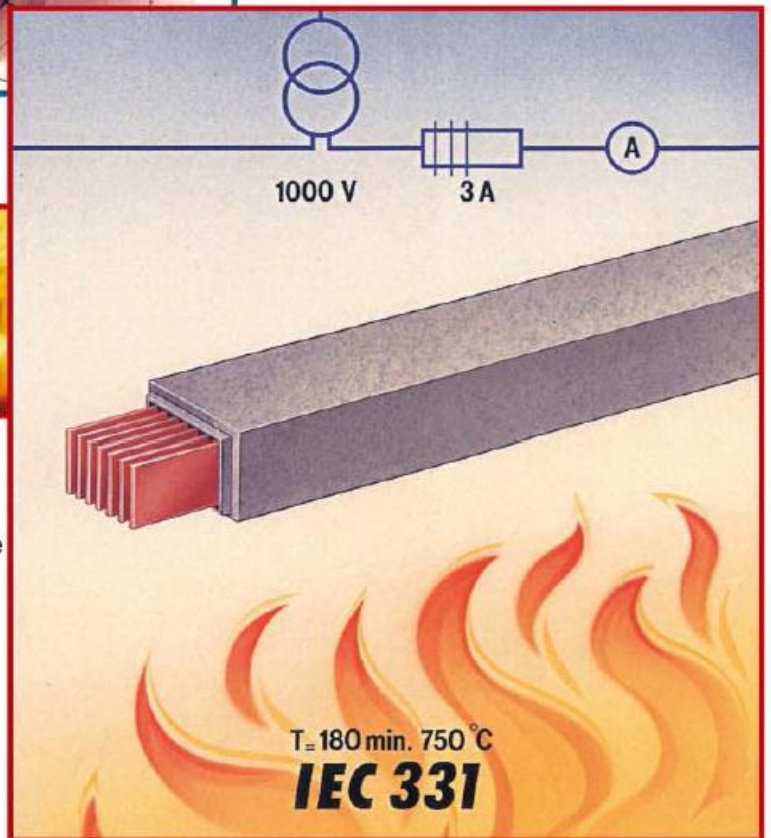







# Product Certification

**Intertek** Intertek Laboratories Taiwan Co., Ltd.  
Contract Inspection and Testing Services (CTS)

進達電業科技(股)有限公司  
Intertek Laboratories Taiwan Co., Ltd.  
11041 台北市內湖區瑞光路二段  
11041 台北市內湖區瑞光路二段  
11041 台北市內湖區瑞光路二段

**Testing Report**

Client Name	TAIN-ETACOM TECHNOLOGY CO. LTD.	Testing Location	Intertek Laboratories Taiwan Co. Ltd.
Address	111, YONG-SUNG CHANG RD., TAIPEI	Address	101, YI-SUNG YW ROAD, TAIPEI
City, State, Zip	TAIPEI	City, State, Zip	TAIPEI
Contact	MR. SHU-LUNG LUNG	Contact	CHIAI-TUNG
Phone	886-2-2727093	Phone	886-2-2642790
Fax	886-2-2705113	Fax	886-2-2646742

Product Description: BM INSULATION MATERIAL

Number of Samples Submitted: 20 pcs

Test Standard of Requirement: UL94 V

Test Results: As attachment

Comments: Nil

Fire withstand examined in accordance with UL 94V

**行政院環境保護署**  
環境保護產品第二類產品證明書

茲據 安達電業科技股份有限公司  
申請環境保護產品第二類產品認證，經核相符，准予認證。  
茲將認證事項如下：

- 一、廠商名稱：安達電業科技股份有限公司  
Tain-Hsun Technology  
台北市內湖區瑞光路二段
- 二、廠商地址：111, YONG-SUNG CHANG RD., TAIPEI (City, State, Taiwan (R.O.C.))
- 三、負責人姓名：謝明達 Ming-Min Hsieh
- 四、產品名稱：全線式絕緣材料 (UL 94V-0)  
Cast-Resin Insulated Busbar System Type 1
- 五、生產廠址：安達電業科技股份有限公司  
Tain-Hsun Technology  
台北市內湖區瑞光路二段  
No. 111, YONG-SUNG CHANG RD., TAIPEI CITY, TAIWAN (R.O.C.)
- 六、產品用途：配電  
Distribution
- 七、環保特性：符合 RoHS 指令 (Restriction of Hazardous Substances)  
符合 RoHS 指令 (Restriction of Hazardous Substances)
- 八、有效期：中華民國九十九年七月二十八日起至  
中華民國九十九年九月二十八日止

沈世宏  
Intertek Product Inspection Services (Taipei) Co., Ltd.

中華民國九十九年七月二十八日

(本證明書僅供該產品認證項目)

Green Mark

**TEST REPORT N° 60058075-559042**

DELIVERED TO: TET  
N°158 SHIN ROAD  
220 YANG-MEI TACHUAN HSEIN  
TAIWAN ROC

SUBJECT: Tested Product: POLYMER CONCRETE  
Reference BIM-7W-GY253-07  
On the basis of the LCIE ET ATEX 0003U certified product.

Date of the tests: July 20<sup>th</sup>, 2007 to December 4<sup>th</sup>, 2007  
This document contains 12 pages  
Appendix: C survey report N: 315 922

Fortelajau-Rose, January 07<sup>th</sup>, 2008  
The Technical Manager  
Name: David RAVEAU

Signature:

© LUL Technology Services  
Optimise and integrate the energy and materials  
and outside the scope of MAMAS accreditation

Test Report of LCIE  
1) Light resistance tests.  
2) Dielectric rigidity tests.  
3) Electrostatic charge tests.

**LUL TECHNOLOGY SERVICES**  
LUL Technology Services  
Pirelli Road  
MILANO  
Attn: LULUL ET ATEX  
Telephone: +39 02 71 938433  
Fax: +39 02 71 938438

Report No. C10399

**FIRE SAFETY ASSESSMENT OF BETOBAR-R BUSBAR SUPPLIED BY PIRELLI CONSTRUCTION**

Prepared for: Mr. M. Payne  
Pirelli Construction  
PO Box 6, Leigh Road, Eastleigh, Hampshire, SO50 9YE

Issue Date: 19-Aug-1996

Reference: 6220-DJS-C10399-TSK14750

Prepared by: D.J. Sanghurst  
Signature:

Certified by: J.L. Udelski  
Signature:

© LUL Technology Services  
Optimise and integrate the energy and materials  
and outside the scope of MAMAS accreditation

Low smoke and non-toxic gas  
examined by LUL









1. Title:TECOBAR Low Voltage Cast-Resin Insulated Busway.

2. Product Description:

TECOBAR Low Voltage Cast-Resin Insulated Busway is developed for electrical systems below 1kV. The product has features of safety and compact. It is designed to use the insulation material to perform cast resin sealing to the copper (aluminium) conductor. The insulation material is cast resin which contains non-organic volcanic rock with the features of excellent insulation characteristics, mechanical strength, humidity-proof, non-combustible, and self-extinguishing .

3. Applicable Scope:

TECOBAR busway is manufactured in accordance with IEC 60439-1, IEC 60439-2, IEC 61439 and CNS 14286. The elements included as below:

3.1 Straight elements, elbow elements, geometrical shape elements, phase-switch elements, expansion elements, transfer elements, split elements and terminal elements.

3.2 Distribution unit: There are fixed type take-off unit and draw-out type plug-in unit.

\* Note: The plug-in leads shall be reserved in advance. Therefore, the number of plug-in unit shall be confirmed while purchase.

4.Condition of Use:

TECOBAR busway is composed of the elements listed in item 3.1. The elements are connected through junction units on site before cast molding with insulation mix to complete the low voltage busway.

Conditions for TECOBAR:

4.1 Altitude: below 2000m, indoor and outdoor site.

4.2 Ambient temperature: -45°C~65°C

4.3 Ambient humidity: 0%~100%

5. Technical Specifications:

5.1 Rated Voltage V : AC1000V.

5.2 Rated Current A : 419A~8421A.

5.3 Frequency Hz : 50/60.

5.4 System : 3 $\phi$ 3w, 3 $\phi$ 4w, 3 $\phi$ 3w+1/2G, 3 $\phi$ 3W+G, 3 $\phi$ 4W+1/2G, 3 $\phi$ 4W+G.

5.5 Conductor Material : Copper (E-Cu57) and Aluminum.

Purity : 99.9% Conductivity : Above 98% IACS.

According to standards : JIS H3140 , DIN 1787, DIN 1759, DIN 40500.

5.6 Electrical characteristics of each TECOBAR element (less than 4m)

Insulation capabilities : Ⓒ AC voltage withstand phase to phase is AC 5kV/1min.

Ⓒ Insulation resistance phase to phase is  $\geq 2G \Omega$  /DC 1kV.

Fireproof : Ⓒ In accordance with CNS 14286 at 840°C for 30 minutes.

Ⓒ In accordance with IEC 60331-21 at 750°C for 3 hours.

Ⓒ In accordance with BS 6387 950°C for 3 hours.

Protection degree : Ⓒ In accordance with IEC 60529 IP68.

Mechanical impacts : Ⓒ In accordance with IEC 62262 IK10.

Grounding : Ⓒ Internal grounding for TECOBAR busway system.



## Copper

Type	Single Line								Double Lines		
Model	LA02EC	LA04EC	LA04EC	LA08EC	LA08EC	LA12EC	LA16EC	LA16EC	LA08DC	LA12DC	LA16DC
Conductor Section(mm <sup>2</sup> )	80	160	240	320	400	600	800	960	960	1440	1920
Conductor Dimensions (mm)	w20xt4	w40xt4	w40xt6	w80xt4	w80xt5	w120xt5	w160xt5	w160xt6	2-w80xt6	2-w120xt6	2-w160xt6
Conductor Material	purity copper 99.9% , above 98% IACS										
Rated Current A (35/40 °C)	419	713	874	1127	1263	1622	2008	2221	2624	3442	4202
Rated Voltage V	1000										
Frequency Hz	50/60										

Electrical Characteristics											
R at 20 °C $\mu\Omega / m$	209.0	108.3	72.1	54.1	43.3	28.9	21.7	18.8	18.1	12.1	10.2
R at 90 °C $\mu\Omega / m$	253.9	142.1	94.6	69.3	55.2	39.3	29.5	24.1	24.2	16.6	12.7
X $\mu\Omega / m$ f:60Hz	98.4	89.6	86.6	74.1	73.2	58.9	46.4	45.7	43.9	35.8	28.2
I <sub>cw</sub> kA / 1Sec	15	28	40	50	50	65	80	80	100	120	120
I <sub>peak</sub>	65	84	84	110	110	143	176	176	220	264	264
P <sub>loss</sub> W / m	134	217	217	264	264	310	357	357	500	590	683
IP/IK	IP68/IK10										

※ Technical specifications may change without any further notice.

Product Dimensions (mm)	Width (B) / Height (H)											
	Fig.1	Fig.2	Fig.3	Fig.4	Fig.4	Fig.4	Fig.4	Fig.4	Fig.4	Fig.4	Fig.4	Fig.4
3 $\phi$ 3W (Fig.1)												
3 $\phi$ 4W (Fig.2)												
3 $\phi$ 3W+G (Fig.3, Fig.4)	104/60	104/80	104/80	104/120	104/120	104/160	104/200	104/200	404/120	404/160	404/200	
3 $\phi$ 4W+G (Fig.3, Fig.4)												
Weight kg / m												
Product Weight	13.8	20.3	23.3	33.5	35.7	50.2	64.4	71.5	78.6	111.0	143.0	

※ Conductor : 3 $\phi$ 3W represents R S T three phases, three wires  
 3 $\phi$ 4W represents NRST three phases, four wires.  
 G represents grounding phase 100% of rated current.

※ Please refer to the temperature correction coefficient of rated current on page 1-29 while ambient temperature exceeds 40°C.





# Product Specifications LB

## Copper

Type	Single Line				Double Lines			
Model	LB08EC	LB12EC	LB16EC	LB16EC	LB08DC	LB12DC	LB16DC	LB16DC
Conductor Section(mm <sup>2</sup> )	800	1200	1600	1920	1600	2400	3200	3840
Conductor Dimensions (mm)	2-w80xt5	2-w120xt5	2-w160xt5	2-w160xt6	4-w80xt5	4-w120xt5	4-w160xt5	4-w160xt6
Conductor Material	purity copper 99.9% , above 98% IACS							
Rated Current A (35/40 °C)	2096	2724	3291	3443	4012	5222	6309	6569
Rated Voltage V	1000							
Frequency Hz	50/60							

Electrical Characteristics								
R at 20 °C $\mu\Omega / m$	21.7	14.4	10.8	9.0	10.9	7.2	5.4	4.8
R at 90 °C $\mu\Omega / m$	27.0	18.2	14.0	12.8	14.1	9.4	8.4	7.7
X $\mu\Omega / m$ f:60Hz	33.5	27.2	21.2	20.8	25.9	21.0	16.4	16.1
I <sub>cw</sub> kA / 1Sec	80	100	100	100	120	120	120	120
I <sub>peak</sub>	176	220	220	220	264	264	264	264
P <sub>loss</sub> W / m	356	405	455	455	681	769	997	997
IP/IK	IP68/IK10							

※ Technical specifications may change without any further notice.

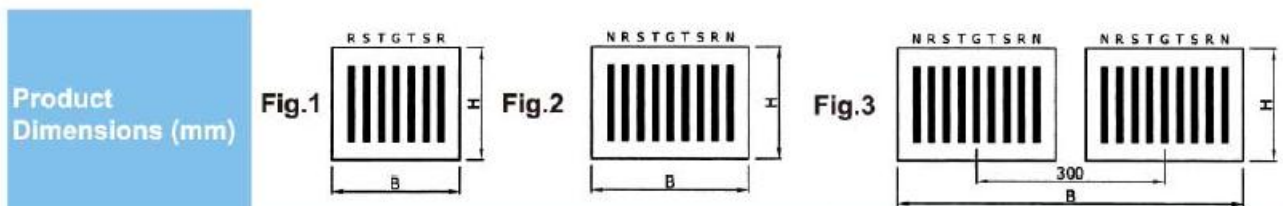

	Width (B) / Height (H)							
3 $\phi$ 3W+1/2G (Fig.1)								
3 $\phi$ 4W+1/2G (Fig.2, Fig.3)	168/120	168/160	168/200	168/200	468/120	468/160	468/200	468/200

	Weight kg / m							
Product Weight	55.1	86.5	111.5	122.0	110.2	173.0	223.0	244.0

※ Conductor : 3  $\phi$  3W represents R S T three phases, three wires.

3  $\phi$  4W represents NRST three phases, four wires.

1/2G represents grounding phase 50% of rated current.

※ Please refer to the temperature correction coefficient of rated current on page 1-29 while ambient temperature exceeds 40°C.



## Aluminum

Type	Single Line						Double Lines		
Model	LA04EA	LA04EA	LA08EA	LA08EA	LA12EA	LA16EA	LA08DA	LA12DA	LA16DA
Conductor Section(mm <sup>2</sup> )	160	240	320	480	600	960	960	1440	1920
Conductor Dimensions (mm)	w40xt4	w40xt6	w80xt4	w80xt6	w120xt5	w160xt6	2-w80xt6	2-w120xt6	2-w160xt6

Conductor Material	AL:1070								
Rated Current A (35/40 °C)	560	686	870	1066	1290	1749	2021	2724	3349
Rated Voltage V	1000								
Frequency Hz	50/60								

Electrical Characteristics									
R at 20 °C $\mu\Omega / m$	176.9	117.9	88.4	58.9	47.2	29.5	29.5	19.7	14.7
R at 90 °C $\mu\Omega / m$	230.9	153.8	116.4	77.5	62.1	38.9	40.8	26.5	20.3
X $\mu\Omega / m$ f:60Hz	89.6	86.5	74.1	72.4	58.9	45.7	43.9	35.8	28.2
Icw kA / 1Sec	15	25	30	50	65	80	100	120	120
Ipeak	84	84	110	110	143	176	220	264	264
P <sub>loss</sub> W / m	217	217	264	264	310	357	500	590	683
IP/IK	IP68/IK10								

※ Technical specifications may change without any further notice.

Product Dimensions (mm)	Fig.1	Fig.2	Fig.3	Fig.4	Width (B) / Height (H)				
3 $\phi$ 3W (Fig.1)									
3 $\phi$ 4W (Fig.2)									
3 $\phi$ 3W+G	104/80	104/120	104/160	104/200	404/120	404/160	404/200		
3 $\phi$ 4W+G (Fig.3, Fig.4)									
Weight kg / m									
Product Weight	15.3	15.8	23.3	24.4	31.1	41.3	48.8	65.4	82.6

※ Conductor : 3  $\phi$  3W represents R S T three phases, three wires.

3  $\phi$  4W represents NRST three phases, four wires.

G represents grounding phase 100% of rated current.

※ Please refer to the temperature correction coefficient of rated current on page 1-29 while ambient temperature exceeds 40°C.





## Aluminum

Type	Single Line			Double Lines	
Model	LB12EA	LB16EA	LB08DA	LB12DA	LB16DA
Conductor Section(mm <sup>2</sup> )	1200	1600	1920	2400	3840
Conductor Dimensions (mm)	2-w120x15	2-w160x15	4-w80x15	4-w120x15	4-w160x15

Conductor Material	AL:1070				
Rated Current A (35/40 °C)	2094	2574	3395	4015	5375
Rated Voltage V	1000				
Frequency Hz	50/60				

Electrical Characteristics					
R at 20 °C $\mu\Omega / m$	23.5	17.7	14.7	11.8	7.4
R at 90 °C $\mu\Omega / m$	30.8	22.9	19.7	15.9	11.5
X $\mu\Omega / m$ f:60Hz	27.2	21.2	25.5	21.0	16.1
I <sub>cw</sub> kA / 1Sec	100	100	120	120	120
I <sub>peak</sub>	220	220	264	264	264
P <sub>loss</sub> W / m	405	455	681	769	997
IP/IK	IP68/IK10				

※ Technical specifications may change without any further notice.

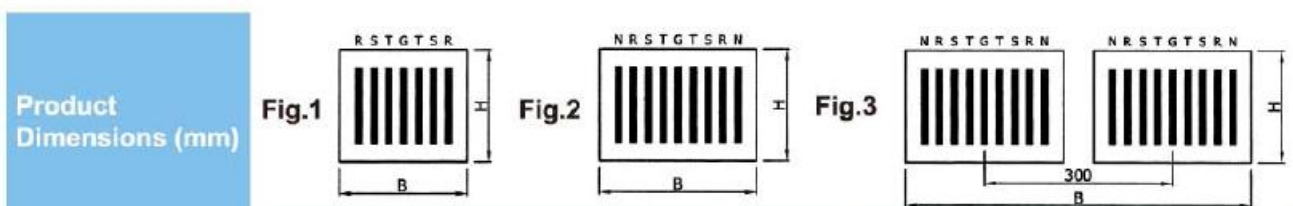

	Width (B) / Height (H)				
3 $\phi$ 3W+1/2G(Fig.1)	168/160	168/200	468/120	468/160	468/200
3 $\phi$ 4W+1/2G (Fig.2 Fig.3)					

	Weight kg / m				
Product Weight	53.5	63.6	79.0	101.1	135.0

※ Conductor : 3 $\phi$  3W represents R S T three phases, three wires.

3 $\phi$  4W represents NRST three phases, four wires.

1/2G represents grounding phases 50% of rated current.

※ Please refer to the temperature correction coefficient of rated current on page 1-29 while ambient temperature exceeds 40°C.



# Copper

Type	Single Line					Double Lines				
Model	NLV16	NLV16	NLV20	NLV20	NLV24	NLV16-D	NLV20-D	NLV24-D	NLV24-D	NLV24-D
Conductor Section(mm <sup>2</sup> )	640	800	1000	1200	1440	1600	2000	2400	2880	3120
Conductor Dimensions (mm)	w160xt4	w160xt5	w200xt5	w200xt6	w240xt6	2-w160xt5	2-w200xt5	2-w240xt5	2-w240xt6	2-w240xt6.5

Conductor Material	purity copper 99.9% , above 98% IACS									
Rated Current A (35/40 °C)	2454	2732	3357	3665	4225	5309	6350	7422	8122	8421
Rated Voltage V	1000									
Frequency Hz	50/60									

Electrical Characteristics										
R at 20 °C $\mu\Omega / m$	27.2	21.7	17.3	14.4	12.0	10.8	8.7	7.2	6.0	5.5
R at 90 °C $\mu\Omega / m$	36.8	29.7	23.6	19.8	16.9	15.4	12.4	10.3	8.6	8.0
X $\mu\Omega / m$ f:60Hz	82.3	81.8	57.8	57.4	30.3	43.1	30.9	16.1	15.9	15.6
I <sub>cw</sub> kA / 1Sec	100	100	120	120	120	120	120	120	120	120
I <sub>peak</sub>	220	220	264	264	264	264	264	264	264	264
P <sub>loss</sub> W / m	665	665	798	798	905	1302	1500	1702	1702	1702
IP/IK	IP68/IK10									

※ Technical specifications may change without any further notice.

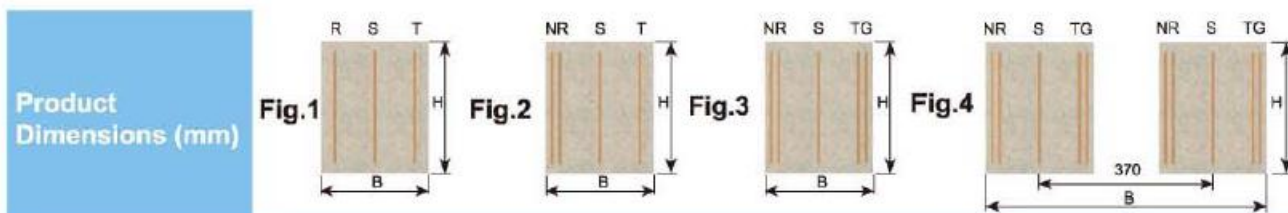

	Width (B) / Height (H)					
3 $\phi$ 3W(Fig.1)						
3 $\phi$ 4W (Fig.2)	230/200	230/240	230/280	600/200	600/240	600/280
3 $\phi$ 4W+G(Fig.3 Fig.4)						

	Weight kg / m									
Product Weight	74.3	91.8	111.6	120.8	162.1	183.6	223.8	302.9	324.2	334.9

- ※ The heat dissipation openings of this series of TECOBAR are unique design patent. This series have granted the patent certificate by Taiwan and China.
- ※ Conductor : 3  $\phi$  3W represents R S T three phase, three wires.  
3  $\phi$  4W represents NRST three phases, four wires.  
G represents grounding phase 100% of rated current.
- ※ Please refer to the temperature correction coefficient of rated current on page 1-29 while ambient temperature exceeds 40°C.





# Product Specifications NLV

Type	Single Line				Double Lines		
Model	NLV16A	NLV16A	NLV20A	NLV24A	NLV16-DA	NLV20-DA	NLV24-DA
Conductor Section(mm <sup>2</sup> )	640	800	1000	1440	1600	2400	2880
Conductor Dimensions (mm)	w160xt4	w160xt5	w200xt5	w240xt6	2-w160xt5	2-w200xt6	2-w240xt6
Conductor Material AL:1070							
Rated Current A (35/40 °C)	1847	2065	2515	3205	4003	5245	6090
Rated Voltage V	1000V						
Frequency Hz	50/60						
Electrical Characteristics							
R at 20 °C $\mu\Omega / m$	44.2	35.4	28.3	19.7	17.7	11.8	9.8
R at 90 °C $\mu\Omega / m$	58.6	46.9	37.9	26.5	25.1	16.4	13.8
X $\mu\Omega / m$ f:60Hz	82.3	81.8	57.8	30.3	43.1	30.2	15.9
I <sub>cw</sub> kA / 1Sec	65	80	120	120	120	120	120
I <sub>peak</sub>	220	220	264	264	264	264	264
P <sub>loss</sub> W / m	600	600	720	817	1175	1354	1536
IP/IK	IP68/IK10						

※Technical specifications may change without any further notice.

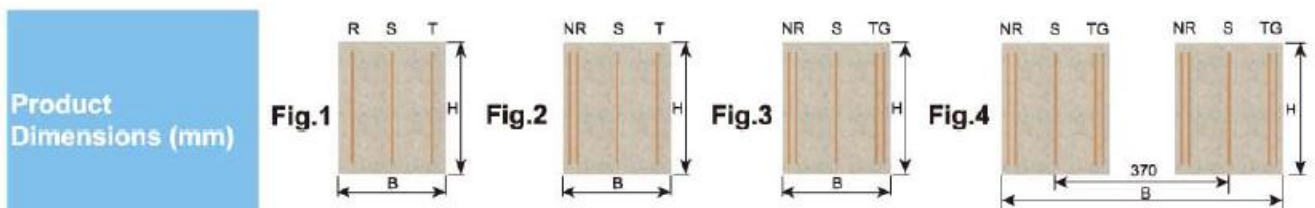

	Width (B) / Height (H)					
3 $\phi$ 3W (Fig.1)						
3 $\phi$ 4W (Fig.2)	230/200	230/240	230/280	600/200	600/240	600/280
3 $\phi$ 4W+G(Fig.3 Fig.4)						

	Weight kg / m						
Product Weight	54.5	67.1	80.7	117.6	134.2	167.4	235.2

※The heat dissipation openings of this series of TECOBAR are unique design patent.

This series have granted the patent certificate by Taiwan and China.

※ Conductor : 3  $\phi$  3W represents R S T three phases, three wires.

3  $\phi$  4W represents NRST three phases, four wires.

G represents grounding phases 100% of rated current.

※ Please refer to the temperature correction coefficient of rated current on page 1-29 while ambient temperature exceeds 40°C.

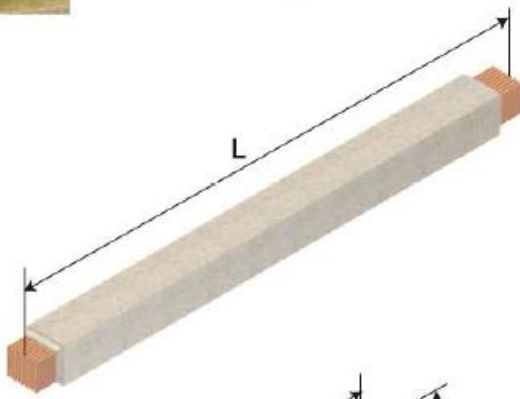

### Straight Element

Model	Length
RE	L=1000mm、2000mm 3000mm、4000mm

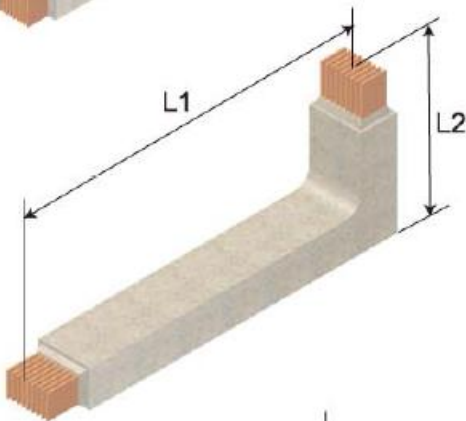

### Brazed Elbow Element

Model	Length
HL1	L1+L2=1000mm
HL2	L1+L2=2000mm
HL1	L1=650mm L2=350mm

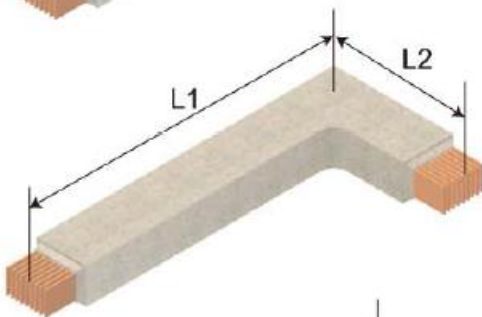

### Bent Elbow Element

Model	Length
HB1	L1+L2=1000mm
HB2	L1+L2=2000mm
HB1	L1=650mm L2=350mm

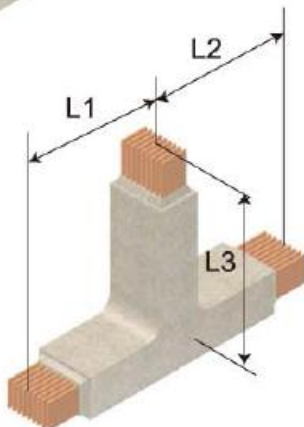

### Brazed T- Element

Model	Length
TL2	L1=L2=L3=350mm

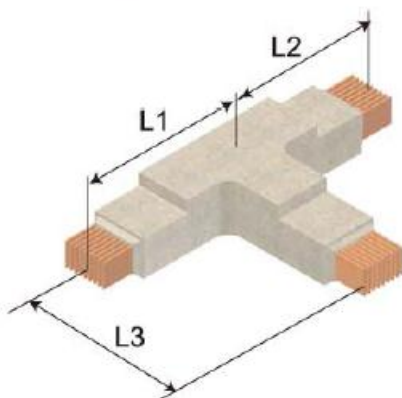

### Bent T- Element

Model	Length
TB2	L1=L2=L3=500mm





# Selection of Standard Parts

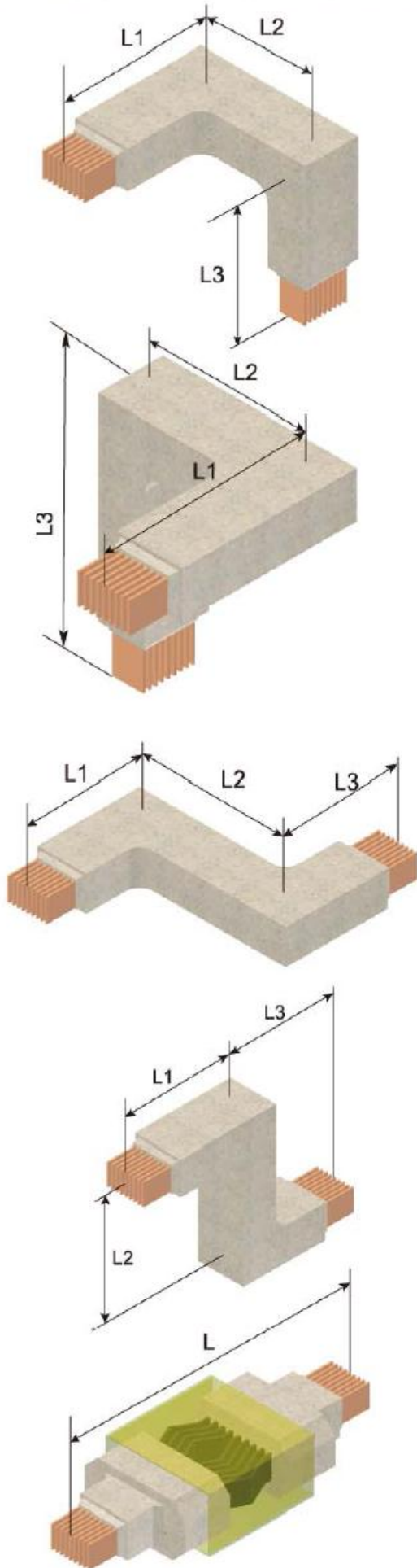

## Double Elbow Element Right

Model	Length
XR1	$L1+L2+L3=1000\text{mm}$
XR2	$L1+L2+L3=2000\text{mm}$
	$L1=L3=350\text{mm}$
	$L2 \geq 701\text{mm}$ , HB+HL applied

## Double Elbow Element Left

Model	Length
XL1	$L1+L2+L3=1000\text{mm}$
XL2	$L1+L2+L3=2000\text{mm}$
	$L1=L3=350\text{mm}$
	$L2 \geq 701\text{mm}$ , HB+HL applied

## Bent Z- Element

Model	Length
ZB1	$L1+L2+L3=1000\text{mm}$
ZB2	$L1+L2+L3=2000\text{mm}$
	$L1=L3=350\text{mm}$

## Brazed Z- Element

Model	Length
ZL1	$L1+L2+L3=1000\text{mm}$
ZL2	$L1+L2+L3=2000\text{mm}$
	$L1=L3=350\text{mm}$

## Expansion Element

Model	Length
EX	$L=1000\text{mm}$ (fixed size)

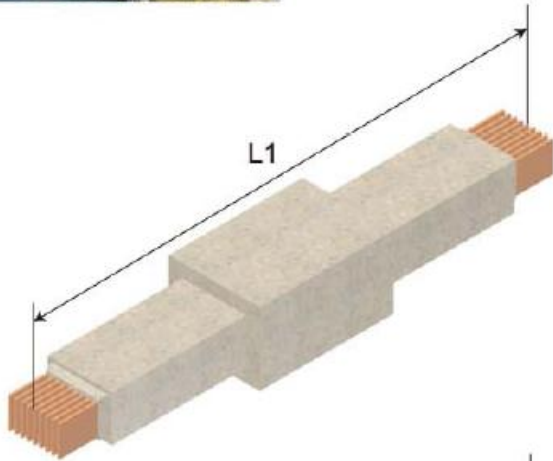

**Phase Switch Element**

Model	Length
PC1	L1=1200mm

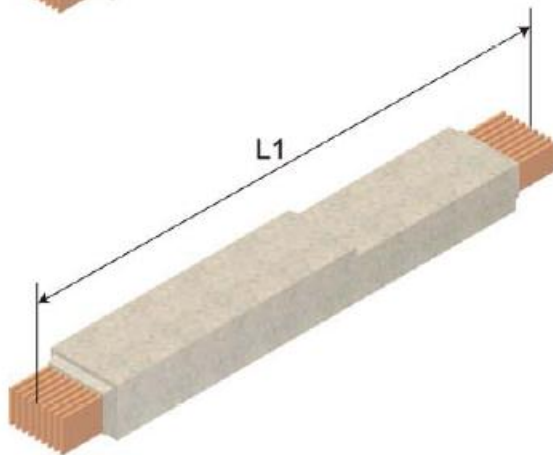

**Transfer Element**

Model	Length
TF1	L1=1200mm

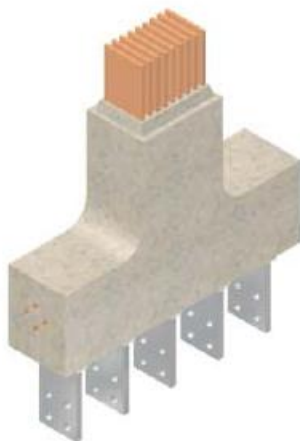

**AG Type Terminal Element**

Model	Length
AG1	Refer to 1-22

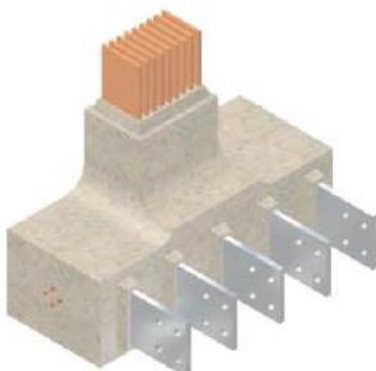

**AO Type Terminal Element**

Model	Length
AO1	Refer to 1-23





# Product Installation

Unit:mm

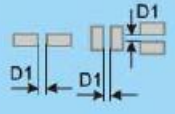
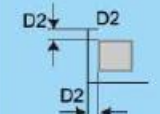
Type	External Size	Limit of Hanger Installation Pitch A		Minimum pitch between busway	
	B × H	Horizontal Installation	Vertical Installation	Layout of Busway arrangement	Distance between opening and busway
LA02	104 × 60	2000	4000		
LA04	104 × 80				
LA08	104 × 120				
LA12	104 × 160				
LA16	104 × 200				
LB04	168 × 80				
LB08	168 × 120				
LB12	168 × 160				
LB16	168 × 200				
NLV16	230 × 200				
NLV20	230 × 240				
NLV24	230 × 280				

Note: Distance between hangers and busway are allowed to be adjusted on site while required.

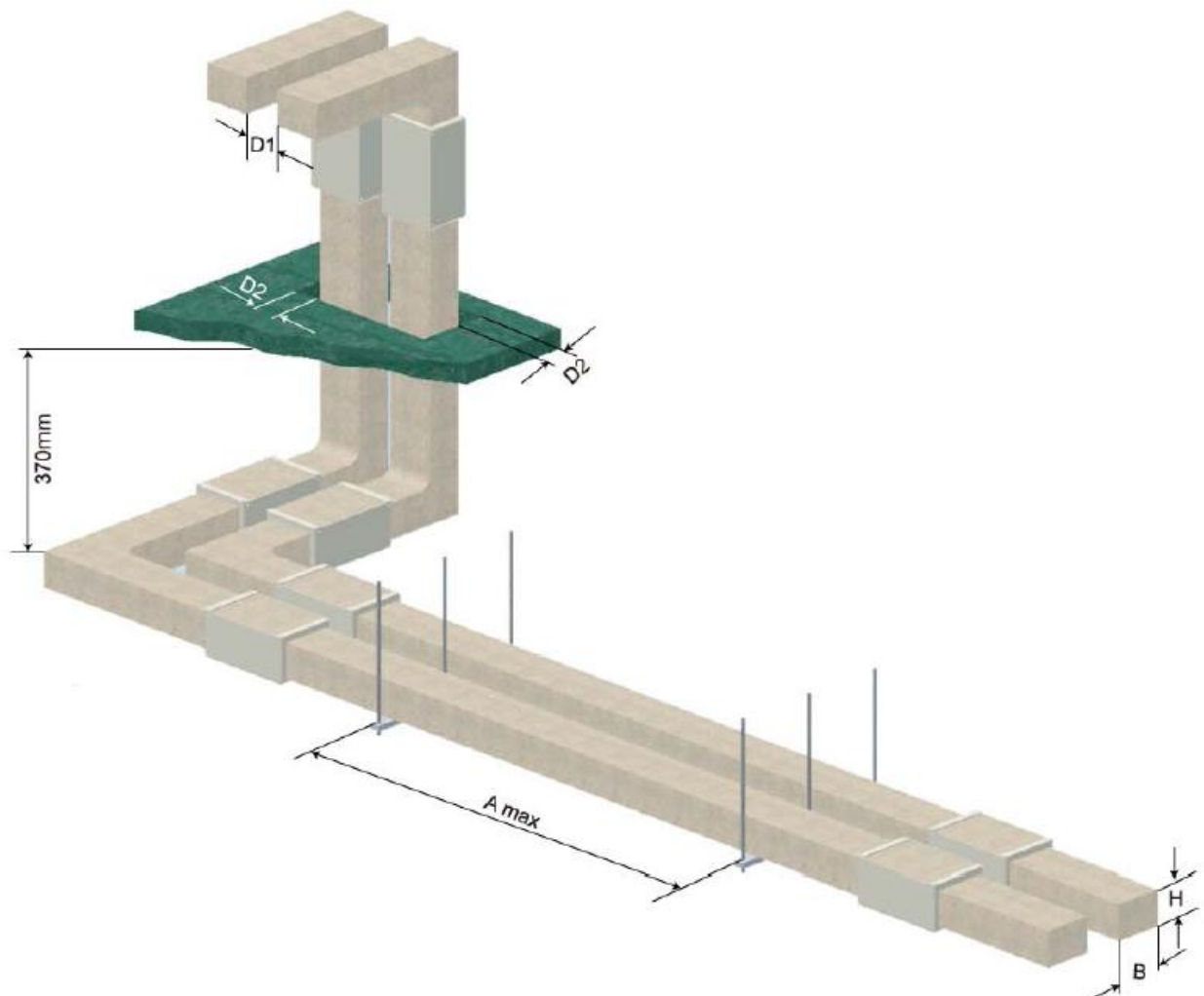



# Assembly Diagrams of Low Voltage Busway Junction



► Distance between two elements are within 20mm (inclusive). The distance can be flexibly adjusted on site by the requirement of construction.

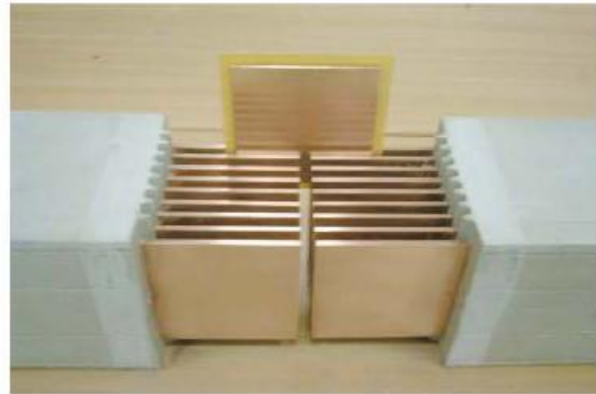

► Illustration of JUNCTION assembly.



► The assembly bolt of Junction must be secured by torque wrench.

### Method of cast-resin work on-site.

Refer to installation guide for casting method on site

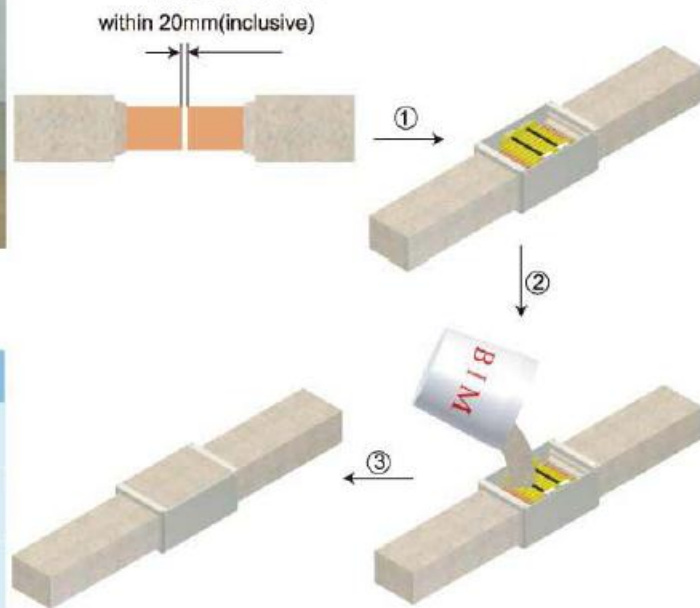

### Torque of bolt during work:

Specs	M10	M12
Torque value (N-m) for Cu	43	74
Torque value (N-m) for Al	30	60

### Illustration of cast-resin after completion.







Unit:mm

# Low Voltage Busway Horizontal Hanger Standard

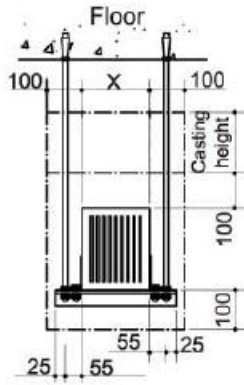

**Cross-sectional Diagram of Single-Busway**

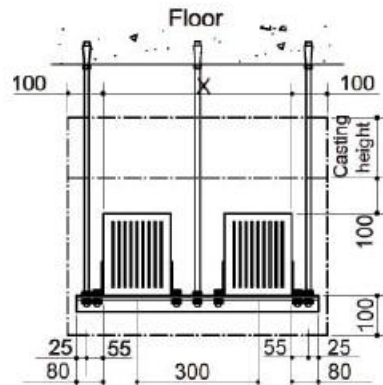

**Cross-sectional Diagram of Dual-Busway**

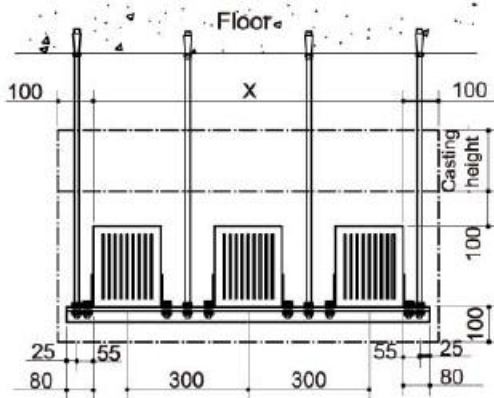

**Cross-sectional Diagram of Triple-Busway**

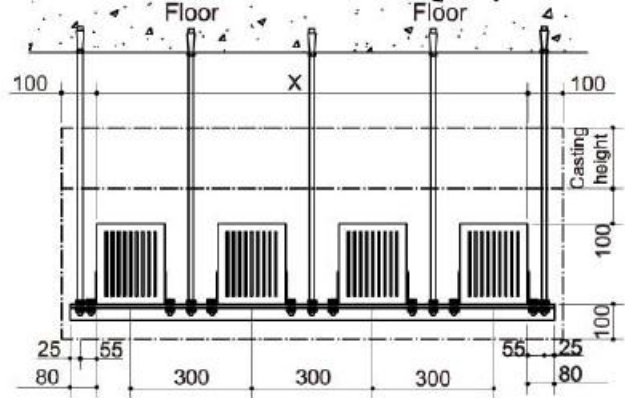

**Cross-sectional Diagram of Quadruple-Busway**

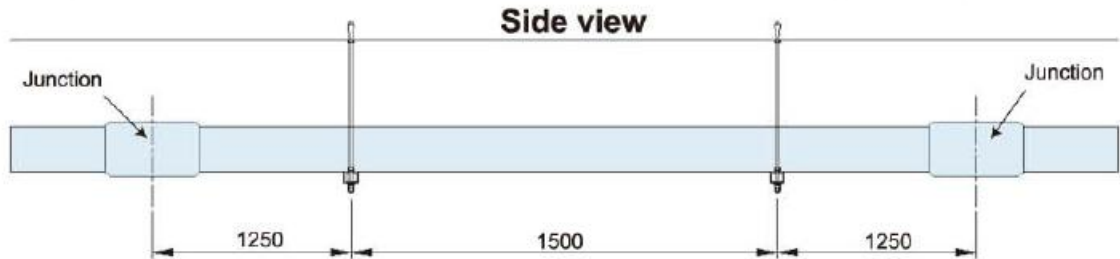

- 1.The installation pitch between each hanger has to comply with the standard as above. If the work condition can not meet the standard, it may be adjusted according to the condition on site. However, it must meet the requirement described in page 18 of the installation guide: minimum pitch requirement of the busway.
- 2.The space required for installing busway is shown in the diagram. The safety space above the busway should have 100mm + casting height of 270mm = 370 mm for clearance standard of installation space. In addition, the height of the floor should be within 5m above the ground to allow expansion of bolts, full-thread bolts, and channel, etc. to install at the bottom of the floor.
- 3.The installation distance of the hanger and corner iron should be in accordance with "x" dimension of busway and dimension listed in the diagram.
- 4.One set of L-shape stopping plate part.

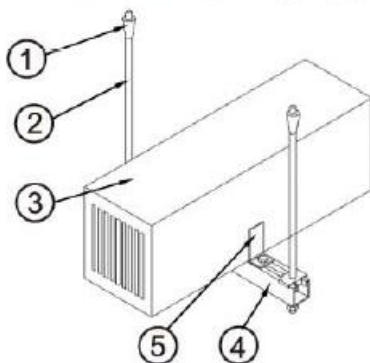

No.	Name of Part	Specs	Remark
①	Inner thread inflated screws	1/2"*2"	Zinc-plated item. (Included in installation work)
②	Full thread bolts	1/2"	Zinc-plated item. (Included in installation work)
③	Busway		TECOBAR
④	Channel	2t*41*41mm	Zinc-plated item. (Included in installation work)
⑤	L-shape stopping plate	2.3t*80*40	Zinc-plated item.



# Low Voltage Busway Vertical Hanger Standard

Vertical Hanger Units			
No.	Name of Part	Specs	Remark
①	Spring Box	-	Zinc-plated item.
②	Upper bolts	M12withN , W , SW	Zinc-plated item.
③	Under bolts	M12withN , W , SW	Zinc-plated item.
④	Channel	100x50x5t	Zinc-plated item. (Included in installation work)
⑤	Inflated Screws	1/2"	Zinc-plated item. (Included in installation work)

※The selection of spring box is according to different busway type.

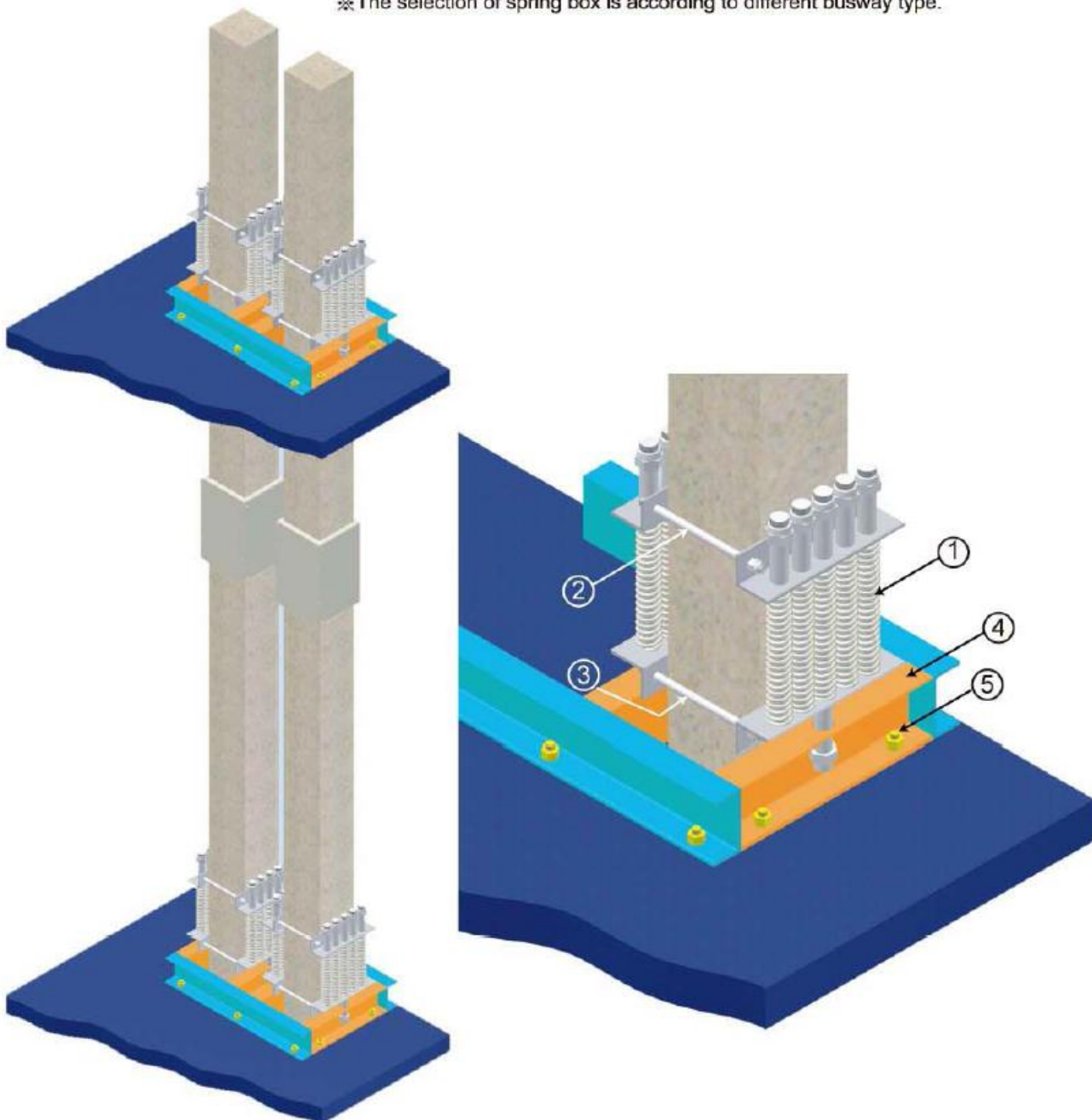





## AG Type Terminal Elements

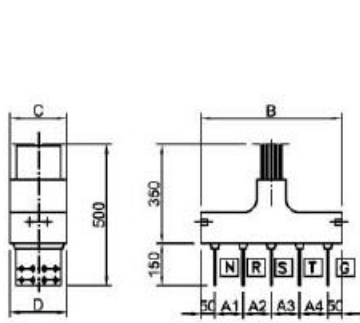

Figure 1

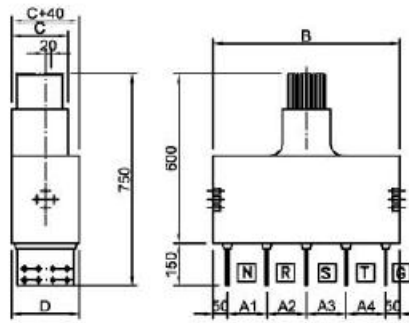

Figure 2

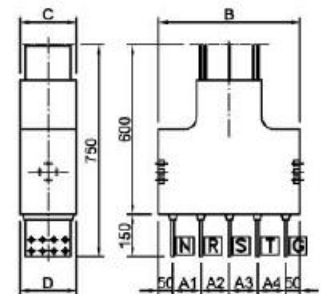

Figure 3

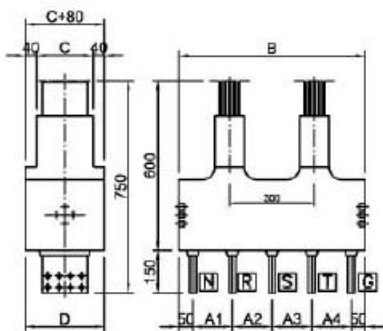

Figure 4

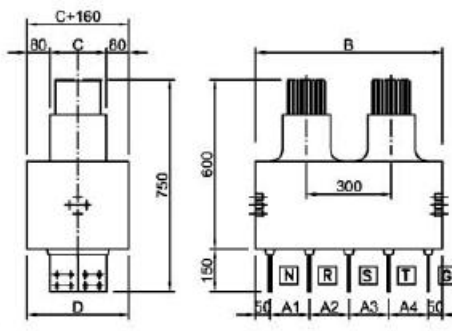

Figure 5

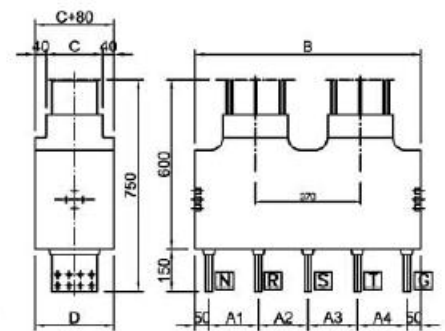

Figure 6

Unit:mm

Figure No.	Type	3 $\phi$ 4W+G or 3 $\phi$ 4W+1/2G(NRSTG)							3 $\phi$ 4W(NRST) or 3 $\phi$ 3W+1/2G(RSTG)					
		A1	A2	A3	A4	B	C	D	A1	A2	A3	B	C	D
Figure 1	LA02EC	100	100	100	100	500	60	60	100	100	100	400	60	60
	LA04EC	100	100	100	100	500	80	80	100	100	100	400	80	80
	LA08EC	100	100	100	100	500	120	120	100	100	100	400	120	120
	LA12EC	100	100	100	100	500	160	160	100	100	100	400	160	160
	LA16EC	100	100	100	100	500	200	200	100	100	100	400	200	200
Figure 2	LB08EC	140	140	140	140	660	120	160	140	140	140	520	120	160
	LB12EC	140	140	140	140	660	160	200	140	140	140	520	160	200
	LB16EC	140	140	140	140	660	200	240	140	140	140	520	200	240
Figure 3	NLV16	100	100	100	100	500	200	200	100	100	100	400	200	200
	NLV20	100	100	100	100	500	240	240	100	100	100	400	240	240
	NLV24	100	100	100	100	500	280	280	100	100	100	400	280	280
Figure 4	LA08DC	140	140	140	140	660	120	200	140	140	140	520	120	200
	LA12DC	140	140	140	140	660	160	240	140	140	140	520	160	240
	LA16DC	140	140	140	140	660	200	280	140	140	140	520	200	280
Figure 5	LB08DC	140	140	140	140	660	120	280	140	140	140	560	120	280
	LB12DC	140	140	140	140	660	160	320	140	140	140	560	160	320
	LB16DC	180	180	180	180	820	200	360	180	180	180	640	200	360
Figure 6	NLV16-D	175	175	175	175	800	200	280	175	175	175	625	200	280
	NLV20-D	175	175	175	175	800	240	320	175	175	175	625	240	320
	NLV24-D	175	175	175	175	800	280	360	175	175	175	625	280	360



**AO Type Terminal Elements**

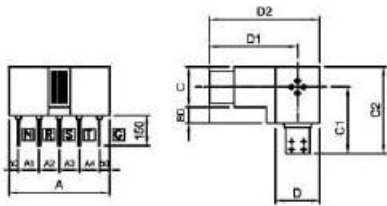

**Figure 1**



**Figure 2**

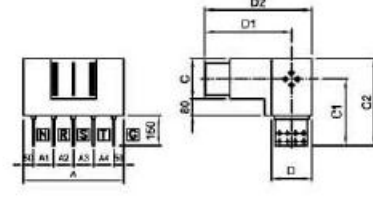

**Figure 3**

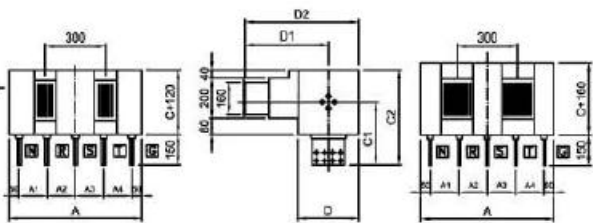

**Figure 4**

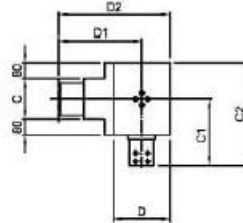

**Figure 5**

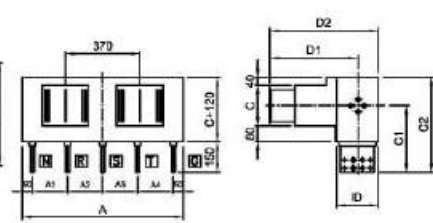

**Figure 6**

Unit:mm

Figure No.	Type	3 φ 4W+G or 3 φ 4W+1/2G(NRSTG)										3 φ 4W(NRST) or 3 φ 3W+1/2G(RSTG)										
		A	A1	A2	A3	A4	C	C1	C2	D	D1	D2	A	A1	A2	A3	C	C1	C2	D	D1	D2
Figure 1	LA02EC	500	100	100	100	100	60	260	290	60	380	410	400	100	100	100	60	260	290	60	380	410
	LA04EC	500	100	100	100	100	80	270	310	80	370	410	400	100	100	100	80	270	310	80	370	410
	LA08EC	500	100	100	100	100	120	290	350	120	390	450	400	100	100	100	120	290	350	120	390	450
	LA12EC	500	100	100	100	100	160	310	390	160	410	490	400	100	100	100	160	310	390	160	410	490
	LA16EC	500	100	100	100	100	200	330	430	200	430	530	400	100	100	100	200	330	430	200	430	530
Figure 2	LB08EC	660	140	140	140	140	120	290	390	220	420	530	520	140	140	140	120	290	390	220	420	530
	LB12EC	660	140	140	140	140	160	310	430	260	440	570	520	140	140	140	160	310	430	260	440	570
	LB16EC	660	140	140	140	140	200	330	470	300	460	610	520	140	140	140	200	330	470	300	460	610
Figure 3	NLV16	500	100	100	100	100	200	330	430	200	430	530	400	100	100	100	200	330	430	200	430	530
	NLV20	500	100	100	100	100	240	350	470	240	470	590	400	100	100	100	240	350	470	240	470	590
	NLV24	500	100	100	100	100	280	370	510	280	510	650	400	100	100	100	280	370	510	280	510	650
Figure 4	LA08DC	660	140	140	140	140	120	290	390	220	380	490	520	140	140	140	120	290	390	220	380	490
	LA12DC	660	140	140	140	140	160	310	430	260	400	530	520	140	140	140	160	310	430	260	400	530
	LA16DC	660	140	140	140	140	200	330	470	330	420	570	520	140	140	140	200	330	470	330	420	570
Figure 5	LB08DC	660	140	140	140	140	120	290	430	310	515	670	560	140	140	140	120	290	430	310	515	670
	LB12DC	660	140	140	140	140	160	310	470	350	535	710	560	140	140	140	160	310	470	350	535	710
Figure 6	LB16DC	820	180	180	180	180	200	330	510	390	605	750	640	180	180	180	200	330	510	390	605	750
	NLV16-D	800	175	175	175	175	200	330	430	200	430	530	625	175	175	175	200	330	430	200	430	530
	NLV20-D	800	175	175	175	175	240	350	470	240	470	590	625	175	175	175	240	350	470	240	470	590
	NLV24-D	800	175	175	175	175	280	370	510	280	510	650	625	175	175	175	280	370	510	280	510	650





# Dimensions of Standard Terminal Elements Copper Plate for Low Voltage Busway

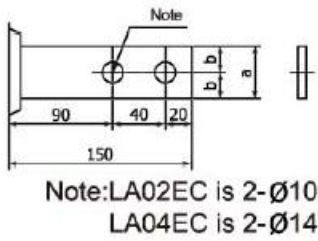

**Figure 1**

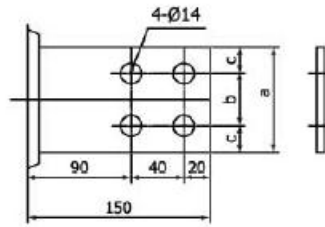

**Figure 2**

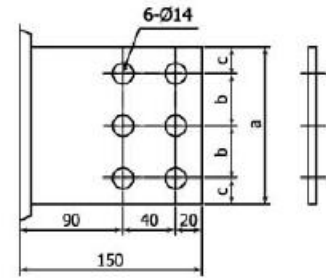

**Figure 3**

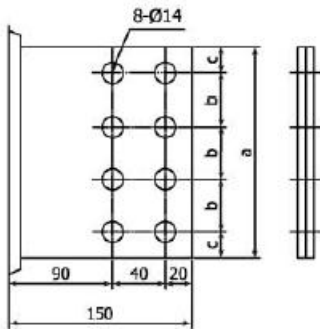

**Figure 4**

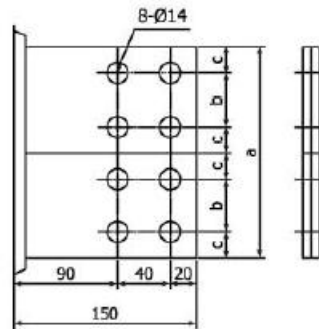

**Figure 5**

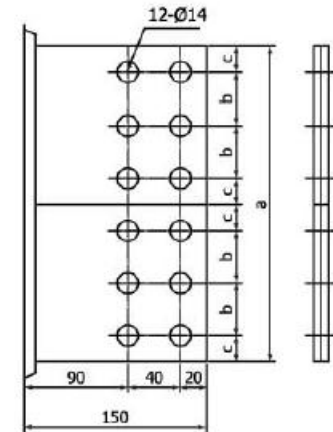
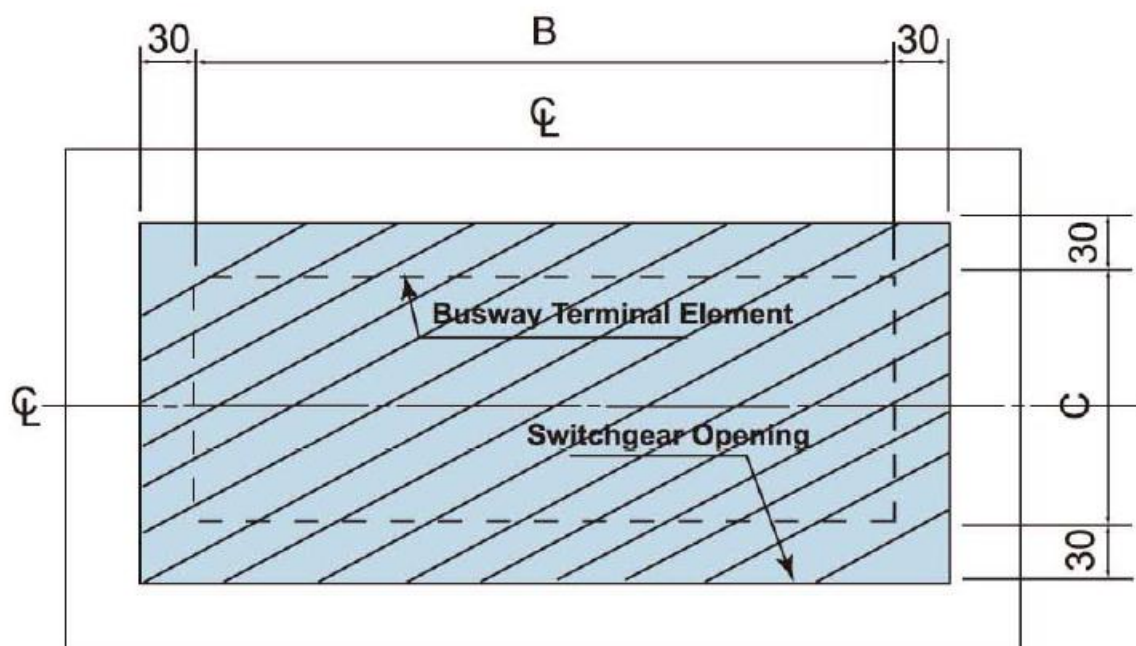

**Figure 6**

Figure	Type	Type of Terminal Elements	Dimensions(unit:mm)		
			a	b	c
Figure 1	LA02EC	AG/AO	20	10	-
	LA04EC	AG/AO	40	20	-
Figure 2	LA08EC	AG/AO	80	40	20
Figure 3	LA12EC	AG/AO	120	40	20
	LB12EC	AG/AO	120	40	20
Figure 4	LA16EC	AG/AO	160	40	20
	NLV16	AG/AO	160	40	20
Figure 5	LB16EC	AG/AO	160	40	20
	LB08DC	AG/AO	160	40	20
	NLV16-D	AG/AO	160	40	20
	LB12DC	AG/AO	200	40	30
	NLV20	AG/AO	200	40	30
	NLV20-D	AG/AO	200	40	30
Figure 6	LB16DC	AG/AO	240	40	20
	NLV24	AG/AO	240	40	20
	NLV24-D	AG/AO	240	40	20



## Opening Dimensions of Switchgear Top, Bottom, and Rear Side



**Busway Terminal Elements Opening Dimensions** Unit: mm

Type	AG Type Terminal Elements		AO Type Terminal Elements	
	C	B	C	B
LA02EC	60	500	60	500
LA04EC	80	500	80	500
LA08EC	120	500	120	500
LA12EC	160	500	160	500
LA16EC	200	500	200	500
LA08DC	200	660	200	660
LA12DC	240	660	260	660
LA16DC	280	660	300	660
LB08EC	160	660	220	660
LB12EC	200	660	260	660
LB16EC	240	660	300	660
LB08DC	280	660	310	660
LB12DC	320	660	350	660
LB16DC	360	820	390	820
NLV16	200	500	200	500
NLV20	240	500	240	500
NLV24	280	500	280	500
NLV16-D	200	800	200	800
NLV20-D	240	800	240	800
NLV24-D	280	800	280	800

Opening Requirement of Standard Terminal Elements and Switchgear for Low Voltage Busway





**Low Voltage Busway Terminal Element and Switchgear Standard Guideline**

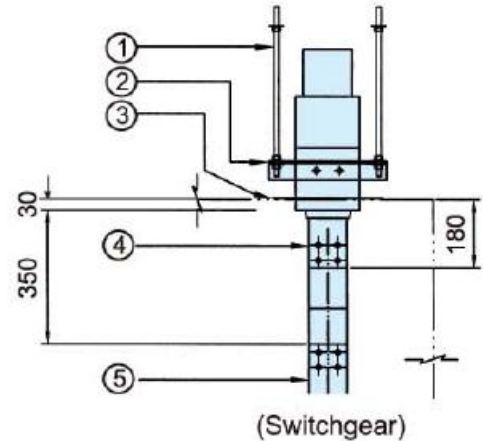
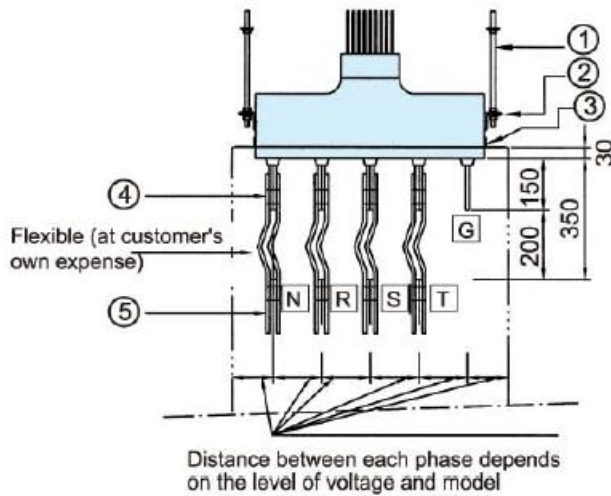
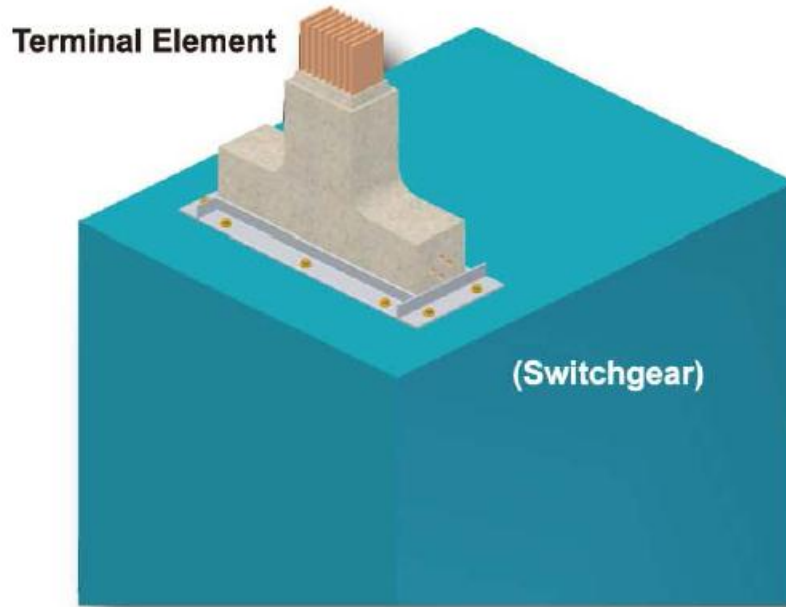

No.	Name	Specs	Remark
1	Full threaded screw	1/2"	Zinc-plated product (Included in installation work)
2	Angle Steel	6t × 50 × 50mm	Zinc-plated product (Included in installation work)
3	Terminal element seal	Steel plate t= 2mm	Painted
4	Flexibles	The 200mm reserved space between terminal element and switchgear are connected by flexibles.	Materials of this portion and connection work does not belong to the busway contractor.
5	Connection copper plate of switchgear	According to Switchgear design.	The drillings on copper plate are designed, processed and connected by switchger contractor.

Note: This diagram is the standard connection interface.  
Actual location of connection is determined case by case.

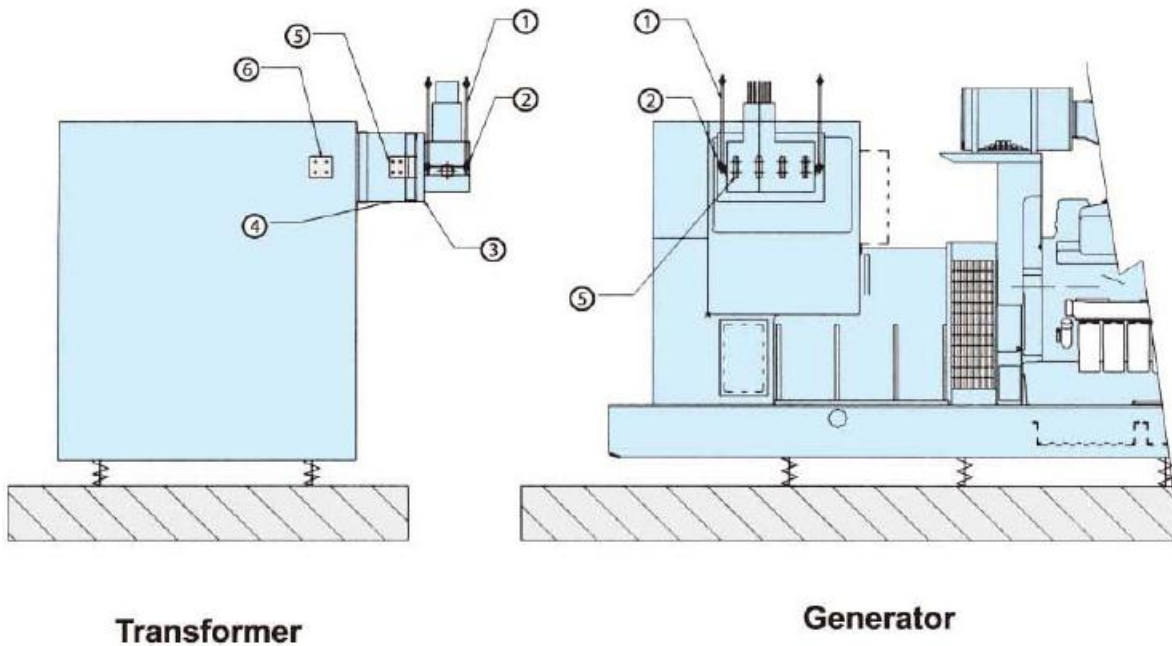

No.	Name	Specs	Remark
1	Full threaded screw	1/2"	Zinc-plated product (Included in installation work)
2	Angle Steel	6t × 50 × 50mm	Zinc-plated product (Included in installation work)
3	Terminal element seal	Steel plate t=2mm	Painted
4	Fireproof cambric	A01	Non-Combusion (Included in installation of flange)
5	Flexibles	The reserved space between terminal element and generator are connected by flexibles.	Materials of this portion and connection work does not belong to the busway contractor.
6	Connection copper plate of generator/transformer	According to Switchgear design.	The drillings on copper plate are designed, processed and connected by switchgear contractor.





# Plug-in Unit

- A. The standard length of each section of plug-in unit type busway is 3m and 4m. The plug-in points should be compared with the quantity and position of MCCB from customer's system drawing. Extra points need to be reserved by customer's actual requirement and the price is determined separately.
- B. When the plug-in unit is taken off, the opening of the leads is sealed by the insulation cover with the protection level IP65.
- C. There is an interlock device between plug-in unit and busway. In order to ensure the safety of operator, the plug-in unit can not be taken off from busway unless MCCB is off.
- D. The "ON/OFF" indication is shown on the cover for operation of plug-in unit. There has an interlock between the cover of plug-in unit and MCCB to make sure when MCCB is turned ON that the cover of plug-in unit can not be opened. (Unlock the cover from outside when MCCB is turned ON, which is another option for customer. The price differs from general type.)
- E. The design of plug-in unit meets the requirement of IEC60529 IP54/IP55. (IP55 is optional, the price is determined separately.)
- F. For minimum distance between busway, please refer to the horizontal/vertical pitch of "Product Installation Description". If the different rated current plug-in unit is installed, the maximum unit size should be used as basis.
- G. The design of plug-in unit fingers and flange connection are patented with M328135, low contact resistance is the major advantage for the design.
- H. The standard colour of plug-in unit is white N-9.5. (The colour is optional.)

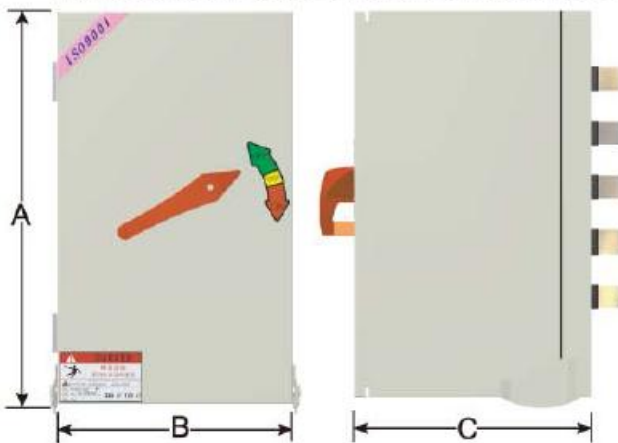

BUSWAY TYPE	CURRENT RATING(A)	DIMENSION(mm) (AxBxC)
3φ4W+G(5P)	125AF,15AT-125AT	350x260x287
3φ4W+1/2G(9P)	125AF,15AT-125AT	500x300x307
3φ4W+G 3φ4W+1/2G	250AF,126AT-250AT	
3φ4W+G 3φ4W+1/2G	400AF,251AT-400AT	600x300x307
3φ4W+G 3φ4W+1/2G	600AF,401AT-600AT 800AF,601AT-800AT	900x350x380
3φ4W+G 3φ4W+1/2G	1600AF,1001AT-1600AT	1350x500x500

Note: 1. Design is based on TO/TG series MCCB of TECO.  
2. MCCB other than TECO is selected, the price is discussed separately.

1. When the plug-in unit is taken off, the opening of the leads must be placed by the insulation cover.
2. Install the basement of plug-in unit.
3. Insert the plug-in unit onto the support plate of basement.
4. Installation completed.

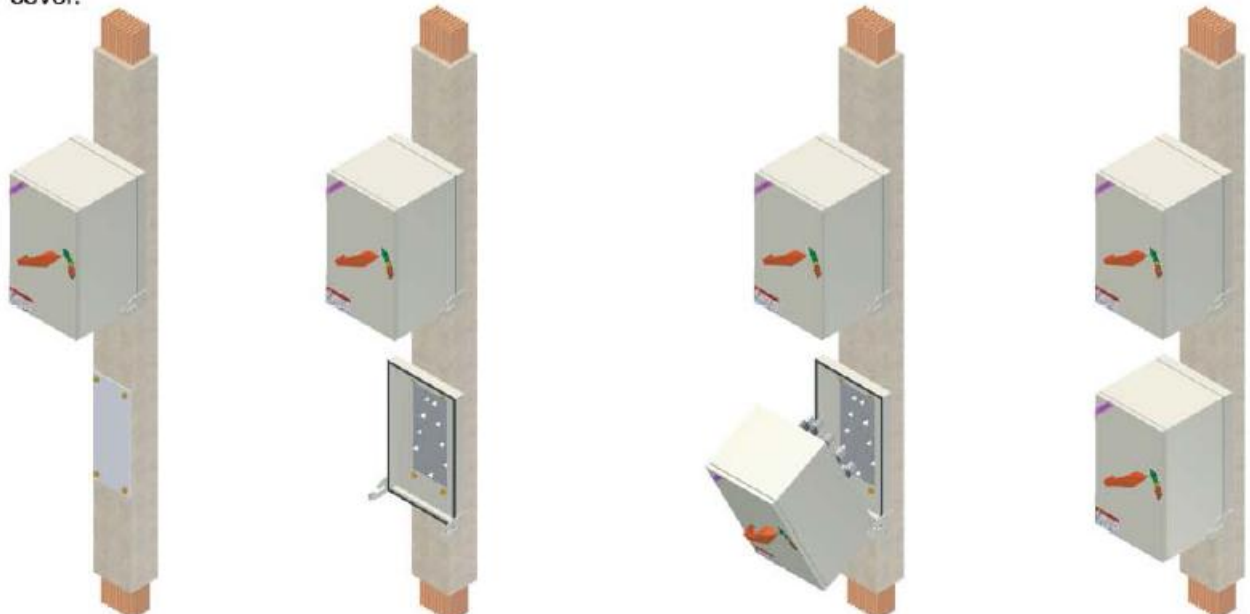



### 1. Temperature correction coefficient for rated current

Maximum ambient temperature °C	20	25	30	35	40	45	50	55	60
Daily average ambient temperature °C	15	20	25	30	35	40	45	50	55
Correction coefficient	1.18	1.14	1.09	1.05	1.00	0.94	0.88	0.82	0.75

### 2. Voltage drop calculation

$$\Delta U = \sqrt{3} \times I_s \times L \times (R \cos \theta + X \sin \theta) \times 10^{-6}$$

$\Delta U$  =Voltage drop (Volts)

$I_s$  =Load current (Amps)

$L$  =Line length (m)

$R$  =Resistance ( $\mu \Omega/m$ )

$X$  =Reactance ( $\mu \Omega/m$ )

$\cos \theta$  =Power factor

$\sin \theta = \sqrt{1 - \cos^2 \theta}$

### 3. Product model identification

**LA 08 E C 5 - 480**

LA	Product series code	LA:Low voltage 1kV LA series NLV:Low voltage 1kV NLV series	LB:Low voltage 1kV LB series
08	Copper bar width	04 w=40mm , 08 w=80mm , 12 w=120mm , 16 w=160mm, 20 w=200mm, 24 w=240mm,	
E	Single/Double conductor of each phase	E Single line	D Double line
C	Conductor type	C Copper conductor	A Aluminium conductor
5	No. of conductors		
480	Cross sectional area of conductor(mm <sup>2</sup> )	480mm <sup>2</sup>	

**4. For calculation of general product data or technical information, please contact with manufacturer or local agency.**





**A. Low voltage busway dielectric tests: Insulation resistance test and power frequency voltage withstand test**

Electrical tests		Insulation resistance test	Power frequency voltage withstand
Standards		TECOBAR	IEC 60439-2
Type	Ur at 60Hz V	R at 1kV DC M Ω	U at 60 Hz 1min V
LA 02-04-08-12-16	1000	2000	5000
LB 04-08-12-16	1000	2000	5000
NLV 16-20-24	1000	2000	5000

**B. Appearance inspection**

The appearance of each element must be inspected. Result to be mentioned in final inspection report.

**C. Dimension inspection**

All dimensions are to be compared with customer's order sheet. Result to be mentioned in final inspection report.

**D. Outgoing test report**

Low voltage parts shall be tested prior to shipment and attached with outgoing test report.





# Projects Reference List

No.	Project	Industry Type	No.	Project	Industry Type
1.	Shih-Ta Integrated Circuit Corp. - Test Building Project	Wafer Foundry	57.	AvanStrate Taiwan Inc.	Electronic Industry
2.	Winbond Electronics Corp., Factory IV	Wafer Foundry	58.	AvanStrate Taiwan Inc. - TF5 Scheduled Repair Project	Electronic Industry
3.	Winbond Electronics Corp., FAB5 Factory	Wafer Foundry	59.	Youngtek Electronics Corp. - New Construction Project of Busway	Electronic Industry
4.	United Microelectronics Corp., Lien-Cheng Factory II	Wafer Foundry	60.	AGC Display Glass Taiwan Co., Ltd., Phase 8 New Factory Construction Project (2)	Electronic Industry
5.	Winbond Electronics Corp. LV	Wafer Foundry	61.	AGC Display Glass Taiwan Co., Ltd., Phase 9 New Factory Construction Project (Follow-up)	Electronic Industry
6.	Phoenix Precision Technology Corporation	Electronic Industry	62.	AGC Display Glass Taiwan Co., Ltd., Phase 9 New Factory Construction Project	Electronic Industry
7.	Phoenix Precision Technology Corporation - FAB5 Factory New Construction Project	Electronic Industry	63.	AvanStrate Taiwan Inc., Phase 3	Electronic Industry
8.	Kingpak Technology Inc. - Factory	Electronic Industry	64.	United Microelectronics Corp. - Southern Taiwan Science Park A12 New Construction Project	Electronic Industry
9.	Wafer Works Corp., Yang-Mei Factory	Electronic Industry	65.	Wafering Technology Corporation - New Factory Construction Project	Electronic Industry
10.	Arima Computer Corp. - Factory	Electronic Industry	66.	OptoTech Corporation (Factory II)	Electronic Industry
11.	Taiwan Mask Corp., - Hsinchu Factory II	Electronic Industry	67.	FAB2A-2 Busway System Project	Electronic Industry
12.	Toplux Technology Co., Ltd.	Electronic Industry	68.	Epistar Corporation - N8 Factory High-Voltage Substation Busway System Project	Electronic Industry
13.	ZyXEL Communications Corp.	Electronic Industry	69.	N6 Factory Chiller Unit CH#7	Electronic Industry
14.	Hwa Tong Electronic Co., Ltd.	Electronic Industry	70.	V Additional Auxiliary Busway System	Electronic Industry
15.	Hwa Tong Electronic Co., Ltd. - Additional Project	Electronic Industry	71.	Wistron Corporation	Electronic Industry
16.	HannStar Display Corp.	Electronic Industry	72.	STATS ChipPAC Taiwan Semiconductor Corp. V Bumping Line 30K Dust-free Room Project	Electronic Industry
17.	Orient Semiconductor Electronics, Ltd.	Electronic Industry	73.	Hwa Tong Electronic Co., Ltd.	Electronic Industry
18.	Winstek Semiconductor Corp.	Electronic Industry	74.	Taiwan Semiconductor Manufacturing Co., Ltd., Solar Energy Plant	Electronic Industry
19.	Lite Vision Corp.	Electronic Industry	75.	United Microelectronics Corp. V Rectification Section	Electronic Industry
20.	ARIMA Display Corp.	Electronic Industry	76.	AGC Display Glass Taiwan Co., Ltd. - Phase 3 New Factory Construction Project	Electronic Industry
21.	Sheng Yu Technology Co., Ltd.	Electronic Industry	77.	United Microelectronics Corp. V Southern Taiwan Science Park CUB	Electronic Industry
22.	ASYS Corporation	Electronic Industry	78.	Solar Technology Inc. Science Park Hsiang-Yun Project (Jung-Hsin Factory) New Construction Project	Electronic Industry
23.	Flow Asia Corporation 7-in-1 Project	Electronic Factory	79.	OptoTech Corporation Phase 2	Electronic Industry
24.	Davicom Semiconductor, Inc., 3-in-1 Project	Electronic Factory	80.	Taiwan Semiconductor Mfg. Co. Ltd. - Central Taiwan Science Park Factory 15, Phase 1 New Construction Project	Electronic Industry
25.	Optodisc Technology Corporation	Electronic Industry	81.	AU Optronics Corp., Hou-Li Factory	Electronic Industry
26.	Formosa Epitaxy Inc.	Electronic Industry	82.	HannStar Display Corp. (Factory in the Southern Taiwan Science Park, Phase 1)	TFT-LCD Factory
27.	Chilisin Electronics Corp.	Electronic Industry	83.	HannStar Display Corp. (Factory in the Southern Taiwan Science Park, Phases 2 & 3)	TFT-LCD Factory
28.	Winstek Semiconductor Corp.	Electronic Industry	84.	Contrel Technology Co., Ltd.	TFT-LCD Factory
29.	HannStar Display Corp. JV Chien-Chen Project	Electronic Industry	85.	Contrel Technology Co., Ltd. Phase 2	TFT-LCD Factory
30.	Powertech Technology Inc.	Electronic Industry	86.	Acer Internet Center	Data Center
31.	Anpec Electronics Corp.	Electronic Industry	87.	Acer Internet Center V Generator	Data Center
32.	Winstek Semiconductor Corp.	Electronic Industry	88.	Acer Internet Center V UPS	Data Center
33.	TOPPAN CFI	Electronic Industry	89.	Cathay Nei-Hu Information Center	Data Center
34.	Powertech Technology Inc., Phase 2	Electronic Industry	90.	Acer Information V Kun-Ke Computer Facilities New Construction Project	Data Center
35.	Powertech Technology Inc., Phase 2 Extension Section Equipment	Electronic Industry	91.	Acer Information V Kun-Ke 4th Floor New Construction Project	Data Center
36.	Realtek Semiconductor Corp.	Electronic Industry	92.	Acer Information V Kun-Ke 5th Floor New Construction Project	Data Center
37.	ZyXEL Communications Corp. V Hsinchu Science Park Factory 4th Floor Renovation Project	Electronic Industry	93.	Acer Information V ABCD No. 4 Generator Busway System Rectification Project	Data Center
38.	United Microelectronics Corp. V Southern Taiwan Science Park R&D Building	Electronic Industry	94.	Acer Information V ABCD No. 4 Generator Busway System Dismantling Project	Data Center
39.	Fu Te Electronics Corp.	Electronic Industry	95.	Myanmar Factory (Project in Myanmar)	Power Plant
40.	Kuang-Han Engineering (Carrefour in Hsin-Chuang City)	Electronic Industry	96.	EVER Energy Co., Ltd.	Power Plant
41.	GIO Optoelectronics Corp. V Factory II New Construction Project	Electronic Industry	97.	Shih-Lin Ginza Building	Office Building
42.	AGC Display Glass Taiwan Co., Ltd. Phase 10 Factory	Electronic Industry	98.	Pao Shiang Construction & Industrial Co. Building	Office Building
43.	AGC Display Glass Taiwan Co., Ltd. Phase 7 Factory	Electronic Industry	99.	Taoyuan County Government Building	Office Building
44.	AGC Display Glass Taiwan Co., Ltd. Phase 10 Factory, Additional Project	Electronic Industry	100.	Pei-Kang Mazu (Goddess) Temple	Office Building
45.	Toppan Chunghua Electronics Corp.	Electronic Industry	101.	Kaohsiung Fisherman Training Center	Office Building
46.	Song Chuan Precision Co. Ltd. - New Construction Project of Water, Electricity, Fire & Air-conditioning System	Electronic Industry	102.	Ta-Hsin Securities Co. Building	Office Building
47.	Hsinchu Durban Science Park, Phase 8 Factory Building Construction Project	Electronic Industry	103.	Southern Taiwan Science Park Warehouse and Transportation Center	Office Building
48.	Wistron Corporation V Hsin-An Factory High Voltage Power Supply Improvement Project	Electronic Industry	104.	Pfizer Inc.	Office Building
49.	GIO Optoelectronics Corp. - LED Factory New Construction Project Phase 2	Electronic Industry		Cathay Xinyi e-Financial Building	Office Building
50.	NexPower Technology Corp.	Electronic Industry			
51.	Danen Technology Corporation	Electronic Industry			
52.	AGC Display Glass Taiwan Co., Ltd. New Factory Construction Project	Electronic Industry			
53.	Solar City Intl. Co., Ltd. V Chu-Pei Factory New Construction Project	Electronic Industry			
54.	Maico Inc. - New Factory Construction Project	Electronic Industry			
55.	AGC Display Glass Taiwan Co., Ltd., Phase 8 New Factory Construction Project	Electronic Industry			
56.	Solar City Intl. Co., Ltd. Multicrystalline Section Improvement Project	Electronic Industry			





# Projects Reference List

No.	Project	Industry Type	No.	Project	Industry Type
105.	Taiwan Prosperity Chemical Corporation	Office Building	152.	Chunghwa Post V Generator Installation & UPS System	Office Building
106.	Deryunn Commercial Square Building	Office Building		Project of Ai-Kuo Building	
107.	Deryunn Financial Square Building	Office Building		Acer Data Center V Kun-Ke Basement	Office Building
108.	Longshan Temple Library	Office Building	153.	New Construction Project	Office Building
109.	Cathay Financial Information Building	Office Building		Shin Kong Life Insurance Co., Ltd. V New Construction	Office Building
110.	Bao Chen Construction Co., Ltd. Building	Office Building	154.	Office of Multi-purpose Building on Shih-Shang Road	Office Building
111.	Taipower Headquarters Substation	Office Building		Chi-Hsing Technology Co., Ltd. V New Building	Office Building
112.	Taiwan Prosperity Chemical Corporation	Office Building	155.	Construction Project	Office Building
113.	Nangang Software Park, Phase 2	Office Building	156.	Tung-Kang Post Office Construction Project	Office Building
114.	Nangang Software Park, Phase 2	Office Building	157.	Tung-Kang Post Office - New Air-conditioning	Office Building
115.	Taiwan Prosperity Chemical Corporation	Office Building		System Construction Project	
116.	Taipower Headquarters Substation	Office Building	158.	Taipower Co. - Pingtung Chao-Chou Service Office	Office Building
117.	Chunghwa Telecom, Inc. Building V Ministry of Transport & Communications Building	Office Building	159.	Academia Sinica - Agricultural Technology Building Additional Construction Project	Office Building
118.	Shung Ye Group, Chungli Office	Office Building	160.	Kelti International Co., Ltd. V Xinyi Building Additional Engineering Project (ATS Panel)	Office Building
119.	Nangang Police Station	Office Building	161.	Chenghua District Office Building V Busway Replacement Project	Office Building
120.	Institute of Atomic and Molecular Sciences of Academia Sinica V Generator Replacement Project	Office Building	162.	China Steel Corp. - Headquarters Building Electrical Engineering Project	Office Building
121.	Taipower Northwest District Office Emergency Supply Maintenance Building	Office Building	163.	Chien-Chin Post Office New Building Construction Project	Office Building
122.	Ministry of National Defense V Air Conditioning Section of the Po-Ai Program	Office Building	164.	Southern Taipei District Office - Material Building Plumbing & Electricity Work Project	Office Building
123.	Taipower Pingtung District Office - Air Conditioning Section National Tax Administration of Northern Taiwan Province, Minister of Finance - New Office Construction Project	Office Building	165.	Taipower Co., Pingtung Chao-Chou Service Office - Additional Work Project	Office Building
124.	Environment Protection Administration of Executive Yuan - Office Building Structural Reinforcement & Internal Space Improvement Project	Office Building	166.	M.O.F. National Tax Administration of Central Taiwan Province V Taichung County Branch Office Construction Project	Office Building
125.	Year Round Technology Corp. - New Office Building Construction at Cheng-Tai Road of Wu-Ku Township	Office Building	167.	Taipei Tax Office, 2nd Floor Computer Facilities V Mechanical & Electrical Engineering Project	Office Building
126.	Protrend Co., Ltd. - Headquarters Building in Nei-Hu District	Office Building	168.	Changhua District Office, Pei-Tou Service Station Construction Project	Office Building
127.	Lite-On Semiconductor Corp. - Additional Engineering Project	Office Building	169.	Taichung Tax Office, 5th Floor Computer Facilities - Mechanical & Electrical Engineering Project	Office Building
128.	Fu-Mao Construction Co., Ltd. V Sheng-Hsing Section Engineering Project	Office Building	170.	National Tax Administration of Northern Taiwan Province - Taipei County Building Project	Office Building
129.	Academia Sinica - Agricultural Technology Building Construction Project	Office Building	171.	Hsi-Chih Science Park V Xi-Liu Technology New Construction Project	Office Building
130.	Taipower Co., Taoyuan District West Zone Office - Repair & Maintenance Building Busway System	Office Building	172.	Taichung Bureau of Health Promotion	Office Building
131.	Research Center for Humanities and Social Sciences of Academia Sinica - Emergency Generator Equipment	Office Building	173.	Chungsho City Land Administration and Tax Office	Office Building
132.	Taoyuan Irrigation Association	Office Building	174.	Taipower Co., Dispatch Control Center Hsin-Chuang Secondary City Center Central Government	Office Building
133.	Chunghwa Telecom, Inc. Building UPS Circuit Additional and Rectification Project	Office Building	175.	Joint Service Office Building Construction Project V Plumbing & Electricity Engineering Contract	Office Building
134.	Tainan County Environmental Science and Technology Park Building	Office Building	176.	China Steel Corp. - Headquarters Construction Project V Generator Contract	Office Building
135.	Taiwan Prosperity Chemical Corporation (LV)	Office Building	177.	Miaoli County Government V Additional Project	Office Building
136.	Taiwan Prosperity Chemical Corporation V 2nd Floor Additional Project	Office Building	178.	Hua Nan Bank Head Office - World Trade Center Plumbing, Electricity and Air Conditioner Contract	Office Building
137.	Kelti International Co., Ltd. V Xinyi Building Construction Project	Office Building	179.	Li-Yu-Tan Plant V No. 2 Transformer Busway Replacement Contract	Water Works
138.	Kaohsiung Po-Ai Building	Office Building	180.	Sheng Yu Steel Co. - Factory Building Expansion Contract	Iron & Steel
139.	Hou-Li Extra-high Voltage Substation Construction Project	Office Building	181.	China Steel Corp. - Mechanical Work Contract	Iron & Steel
140.	Chunghwa Post V Additional Project of Ai-Kuo Building	Office Building	182.	Hsinchu Science Park V Warehouse & Transportation Center Phase 1	Logistics Center
141.	Rear Block Computer Facilities	Office Building	183.	Yang Ming Marine Transport Corp. - Kaohsiung Cold-storage Warehouse & Logistics Center	Logistics Center
142.	The Technology Center of the Criminal Investigation Bureau, National Police Agency of the Ministry of the Interior	Office Building	184.	Yang Ming Marine Transport Corp. - Air- Conditioner Contract for New Construction Project	Logistics Center
143.	Power Distribution Center of Changhua District Office V Material Building Plumbing & Electricity Work Project	Office Building	185.	Tainan Artillery School	School
144.	Miaoli County Government	Office Building	186.	Nan Jeon College of Technology	School
145.	China Airlines Park Development & Construction Project	Office Building	187.	National University of Kaohsiung	School
146.	Taiwan Prosperity Chemical Corporation EPC (Vapor)	Office Building	188.	Wu Feng University	School
147.	Changhua District Office Building Air-conditioning System Replacement Project	Office Building	189.	Fooyin Institute of Technology	School
148.	Southern Taipei District Office - Material Building Air-conditioning System Project	Office Building	190.	Tzu Chi University, College of Medicine V Life Building Project	School
149.	Cathay World Building Facility Replacement Project	Office Building	191.	National Taiwan Ocean University	School
150.	Investigation Bureau of the Ministry of Justice V Kaohsiung Office Construction Project	Office Building	192.	National Chiao Tung University, Taipei Campus	School
151.	Fire Department of Taoyuan County Government- Office Building Construction Project	Office Building	193.	Shu-Te University	School
			194.	Ilan Institute of Technology	School
			195.	AR-LG Phase 2	School
			196.	Army Academy	School





No.	Project	Industry Type	No.	Project	Industry Type
197.	National University of Kaohsiung, College of Law	School	240.	Fullon Hotels & Resorts - Busway Repair and Maintenance Project	Bank, hotel, department store
198.	National Huwei Institute of Technology	School	241.	Kaohsiung Talee Department Store	Bank, hotel, department store
199.	Wu Feng Institute of Technology	School	242.	Kaohsiung Talee Department Store - Additional Project	Bank, hotel, department store
200.	National Chiao Tung University Dormitory	School	243.	Vietnam Halong Bay Hotel	Bank, hotel, department store
201.	Fooyin University	School	244.	Radium Kagaya International Hotel Co. - New Construction Project	Bank, hotel, department store
202.	Chia Nan University of Pharmacy & Science	School	245.	Shihlin Electric & Engineering Corp. - Shopping Mall Block Electrical Engineering Contract of the Shih Lin Factory Land Development Project	Bank, hotel, department store
203.	Cardinal Tien College of Healthcare & Management	School	246.	Chu-Pei Sheraton Hotel - New Construction Project	Bank, hotel, department store
204.	National University of Kaohsiung, College of Economic Management	School	247.	E-DA Outlet Mall - New Construction Project	Bank, hotel, department store
205.	National Taiwan University - Public Health Building	School	248.	E-DA Theme Park - New Construction Project	Bank, hotel, department store
206.	Kun Shan University	School	249.	Evergreen Resort Hotel - New Construction Project	Bank, hotel, department store
207.	Wu Feng Institute of Technology	School	250.	Evergreen Resort Hotel - New Construction Project (Additional Work Contract)	Bank, hotel, department store
208.	Academia Sinica V Astronomy & Mathematics Building Construction Project	School	251.	Ding Zan Development Co., Ltd. V Tamsui Fishers Resort Art Plaza and Hotel Construction Project	Bank, hotel, department store
209.	National Taitung University - Administration Building Construction Project	School	252.	Chang Hwa Bank - High-voltage Substation Repair & Maintenance Work Project	Bank, hotel, department store
210.	National Chung Hsing University, College of Social Science & Management Building Construction Project	School	253.	Yamay Theme Park - Theme Hotel Construction Project	Bank, hotel, department store
211.	Yung-Fu Elementary School, Sanchung City, Taipei County V Phase 2 School Building Renovation Project (hardware)	School	254.	K-Hotel (Taipei)	Bank, hotel, department store
212.	Peng-Lai Elementary School, Ta-Tung District, Taipei City V School Building Renovation, Expansion, and Underground Parking Lot Construction Project	School	255.	Formosa Chemicals & Fibre Corp. SM2 Sixth Naphtha Cracker Project	Petrochemical industry
213.	Taipei Physical Education College (Tien-Mu)	School	256.	Oriental Petrochemical (Shanghai) Corporation	Petrochemical industry
214.	Taipei Municipal Chung Shan Girls Senior High School - Combined Educational Building Construction Project	School	257.	Shanghai Chlor-Alkali Chemical Co., Ltd.	Petrochemical industry
215.	National United University, Pa-Chia Campus (College of Engineering & Science) - Phase 1 Building Construction Project	School	258.	Shanghai Coking & Chemical Corp.	Petrochemical industry
216.	Yang Ming University - Laboratory Building Low Voltage Equipment Wiring Replacement and Grounding Improvement Project	School	259.	Yanchang Petroleum (Group) Co., Ltd. V Low-voltage Busway System (Transformer Unit 41)	Petrochemical industry
217.	National Taiwan University, Shui-Yuan Campus - Student Dormitory Construction Project (Plumbing & Electricity Contract)	School	260.	Yanchang Petroleum (Group) Co., Ltd. V Low-voltage Busway System (Transformer #3)	Petrochemical industry
218.	National Taichung Nursing College	School	261.	Yanchang Petroleum (Group) Co., Ltd. V Low-voltage Busway System (Water Supply & Wire Distribution Room)	Petrochemical industry
219.	Taipei Physical Education College (Tien-Mu) - Additional Project	School	262.	Nan Ya Plastic Corp. and Formosa Chemicals & Fibre Corp. - Factory	Petrochemical industry
220.	Shih Chien University V Partial Rectification of Fire Loop Project	School	263.	Nan Ya Plastic Corp. and Formosa Chemicals & Fibre Corp. - Vietnam Nhon Trach Plant Phase 1	Petrochemical industry
221.	National Taiwan University V Room No. 2 Power System Improvement (Phase 2) Project	School	264.	Nan Ya Plastic Corp. and Formosa Chemicals & Fibre Corp. - Vietnam Nhon Trach Plant Phase 2	Petrochemical industry
222.	Taipei Municipal Shilin Junior High School Combined Educational Building Construction Project	School	265.	China Man-Made Fiber Corporation - ASU Factory Construction Project	Petrochemical industry
223.	National University of Kaohsiung, College of Humanities & Social Science - Building Construction Project	School	266.	Tasco Chemical Corp. - New Construction Project	Petrochemical industry
224.	National University of Kaohsiung, College of Humanities & Social Science Building New Construction Project	School	267.	Formosa Chemicals & Fibre Corp. - Hai Feng SM3 Plant	Petrochemical industry
225.	Hsinchu Incinerator	Incinerator	268.	Hua-Hsia Polymer Co., Ltd., PVC Plant	Petrochemical industry
226.	Taitung Incinerator	Incinerator	269.	Nan Ya Plastic Corp. and Formosa Chemicals & Fibre Corp. - Vietnam Nhon Trach Plant Phase 3 (VN2)	Petrochemical industry
227.	Tainan Incinerator	Incinerator	270.	Nan Ya Plastic Corp. and Formosa Chemicals & Fibre Corp. - Vietnam Nhon Trach Plant (third water source for public use)	Petrochemical industry
228.	Hsinchu Incinerator	Incinerator	271.	Yen An Oil Refinery Yanchang Petroleum (Group) Co., Ltd.	Petrochemical industry
229.	Chang Hwa Bank, Taichung Branch	Bank, hotel, department store	272.	Ammonia & Urea Plants in MARY	Petrochemical industry
230.	Lakeshore Hotel Phase 2	Bank, hotel, department store	273.	Formosa Chemicals & Fibre Corp., Ningbo Plant	Petrochemical industry
231.	Far Eastern Department Stores Ltd., Pan-Chiao Branch	Bank, hotel, department store	274.	Formosa Plastic Corp., Mai-Liao Cogeneration Aeration Pool - Low Voltage Panel	Petrochemical industry
232.	Chun-Fu Real Estate Co., Ltd. V Hotel on Min-Sheng Road Project	Bank, hotel, department store	275.	Yantai Raffles Offshore Ltd. F&G Millennium SA Semi-Submersible Drilling Unit (Rockwell) Barefield Semi-submersible Drilling Unit (Hull No. YRO2006-193 Busway System)	Oil drilling platform
233.	Heng-Chang Development Co., Ltd. V Nei-Hu Phase 6 Industrial Zone	Bank, hotel, department store	276.	Hohehaote Oil Refining Project	Oil drilling platform
234.	Taiwan Sugar Corp., Nan-Tzu Wholesale Store	Bank, hotel, department store	277.	National Museum of Prehistory	Museum
235.	Cathay Tainan Shopping Center	Bank, hotel, department store	278.	Chi Mei Medical Center	Hospital
236.	Taiwan Sugar Corp., Jen-Te Shopping Center	Bank, hotel, department store	279.	Taichung Veterans General Hospital	Hospital
237.	Nice Prince Hotel and Nice Plaza V Plumbing, Electricity, Fire and Air-conditioning System Project	Bank, hotel, department store	280.	Taoyuan General Hospital, Hsin-Wu Branch	Hospital
238.	Miramar Resort - New Construction Project	Bank, hotel, department store	281.	National Taiwan University Hospital, Research Building	Hospital
239.	Shilin Shopping Complex - Shopping Mall Block	Bank, hotel, department store	282.	Kaohsiung Medical University, College of Medicine	Hospital
			283.	Changhua Christian Hospital	Hospital
			284.	Lo-Sheng Sanatorium	Hospital





# Projects Reference List

No.	Project	Industry Type	No.	Project	Industry Type
285.	Taichung Hospital	Hospital	335.	Changhua Rayon Factory #1 - Power Equipment of Refrigerant Fluid Crystallization Electric Room	Factory
286.	Hualien County Yu-Li Hospital	Hospital		STATS ChipPAC Taipei Semiconductor Corp. -	
287.	Tou-Liu Hospital - New Construction Project	Hospital	336.	Generator Equipment Expansion Project	Factory
288.	China College of Medical Technology V 2nd Student Dormitory Construction Project	Hospital	337.	Swanor Ind. Co., Ltd. V Factory Building Extension Project	Factory Building
289.	Chi Mei Medical Center	Hospital	338.	TECO Fujian Factory Phase 1 Construction Works	Factory Building
290.	Chiayi Chang Gung Memorial Hospital	Hospital	339.	Tai Technology Co., Ltd. - Factory Building Renovation Project	Factory Building
291.	Hualien Mennonite Christian Hospital - New Construction Project	Hospital	340.	Topcell Solar International Co., Ltd. V Kuan-Yin Factory Construction Project (Phase 2 Dormitory)	Factory Building
292.	Taipei Hospital (Sanchung) Renovation Work Project	Hospital	341.	Topcell Solar International Co., Ltd. V Kuan-Yin Factory Construction Project (Copper Busway)	Factory Building
293.	Kaohsiung Medical University V 2nd Education & Research Building Construction Project	Hospital	342.	Topcell Solar International Co., Ltd. V Kuan-Yin Factory Construction Project (Aluminum Busway System)	Factory Building
294.	Tian Chen Hospital - New Construction Project	Hospital	343.	Topcell Solar International Co., Ltd. V Kuan-Yin Factory 2nd Floor Expansion Project	Factory Building
295.	Kaohsiung Medical College - Old Campus Expansion Project	Hospital	344.	Win Semiconductors Corp. - Hwa Ya Technology Park Factory # 3 Renovation & Electrical Work Project	Factory Building
296.	Tri-Service General Hospital - Renovation Work Project	Hospital	345.	Procrystal Technology Co., Ltd. - Secondary Distribution Project for Machines	Factory Building
297.	Tri-Service General Hospital, Ting-Chou Branch V Power Equipment Replacement Project	Hospital	346.	Chi Mei Lighting Technology Corp. V Factory # 2 Wire Distribution & Automatic Control Project	Factory Building
298.	Taiwan Electric Research and Testing Center	Testing Center	347.	TXC Corporation - Phase 3 Factory Construction Project	Factory Building
299.	Taiwan Electric Research and Testing Center - Solar Cell & Display Laboratory Wire Distribution Project	Testing Center	348.	Procrystal Technology Co., Ltd. - Factory #1 Phase 3 Construction Project	Factory Building
300.	Taiwan Photon Source Synchrotron Accelerator - New Construction Project	Testing Center	349.	Hirose Tech Co., Ltd. V Lung-Tan Factory Construction Project - Electrical Engineering System	Factory Building
301.	Taiwan Mobile Co., Ltd., Customer Service Center	Telecom Engine Room	350.	BAOTEK Inc. - Factory & Office Building Construction Project	Factory Building
302.	Chunghwa Telecom, Inc., Nan Kang Engine Room	Telecom Engine Room	351.	Cheng Loong Corp., Hou-Li Factory V Unit 10 Factory Construction Works	Factory Building
303.	Taiwan Mobile Co., Ltd., Nei-Hu Electro-Optical Building - IDC Engine Room Construction Project	Telecom Engine Room	352.	Te-Lin Enterprise Co., Ltd. V New Construction Project of Factory located at Lot no. 483-3, Kuang-Jung Section, Hsin-Chuang City	Factory Building
304.	New Century InfoComm Tech Co., Ltd. - Panchiao Engine Room Construction Project	Telecom Engine Room	353.	Grand Dynasty Industrial Co., Ltd. V New Construction Project of Factory located at Lot no. 483-1, Kuang-Jung Section, Hsin-Chuang City	Factory Building
305.	Taiwan Mobile Co., Ltd. - New Construction Project	Telecom Engine Room	354.	Yeashin Develop Technology Co., Ltd. - New Construction Project	Factory Building
306.	National Center for High-Performance Computing - Engine Room Expansion Project	Telecom Engine Room	355.	UER Technology Corporation - New Construction Project	Factory Building
307.	Tainan Anping Harbor	Wharf	356.	Tungpei Industrial Co., Ltd. - Precision Bearing Factory (On-site Work)	Factory Building
308.	China Shipbuilding Corp., Keelung Ship Yard V Starboard	Wharf	357.	Taiwan Pxmart V Sha-Tien Factory	Factory Building
309.	China Shipbuilding Corp., Keelung Ship Yard V Portside	Wharf	358.	Taipower Northern District Storage & Transportation Center - New Construction Project	Factory Building
310.	Shanghai Waigaoqiao	Wharf	359.	Shern Yeong Precise Optical Co., Ltd. - Factory Construction Project	Factory Building
311.	Tsoying North Port Wharf V On-shore Power Equipment Repair Work Project	Wharf	360.	Heran Factory & Office Building Construction Project	Factory & Office
312.	Kaohsiung City Y-043 Wharf V On-shore Power Equipment Repair Work Project	Wharf	361.	Chiao Thai Hsing Enterprise Co., Ltd. V Yang-Mei Flour Factory Construction Project	Factory Building
313.	Kaohsiung Port Intercontinental Container Terminal - Phase 1	Wharf	362.	HTC Corporation - Taoyuan Kui-Shan Factory & Office Building Construction Project	Factory Building
314.	TECO Electric & Machinery Co. Ltd., Kuan-Yin Factory	Factory	363.	Changxingdao Shipyard	Shipyard
315.	Romastone Co., Ltd., China Factory	Factory	364.	Waigaoqiao Shipyard	Shipyard
316.	TECO Electric & Machinery Co. Ltd., Wuxi Factory	Factory	365.	Changxingdao Shipyard 1# 2# Dockyard	Shipyard
317.	TECO Electric & Machinery Co. Ltd., Wuxi Factory	Factory	366.	Changxingdao - Min-Pin Project	Shipyard
318.	Yulon Motors (Car Body Plant)	Factory	367.	Tainan High Speed Railway Station	HSR Station
319.	Yulon Motors (Assembly Plant)	Factory	368.	Taichung High Speed Railway Station	HSR Station
320.	Yulon Motors V Car Factory	Factory	369.	Chiayi High Speed Railway Station	HSR Station
321.	Kyodo Kokusan K.K., Tainan Branch	Factory	370.	Yen-Chao High Speed Railway Station	HSR Station
322.	Li-Peng Polymer Co., Ltd.	Factory	371.	Liu-Chia High Speed Railway Station	HSR Station
323.	Li-Peng Polymer Co., Ltd.	Factory	372.	Shin Kong Mitsukoshi Development V Tsoying Station Business Development Zone Project	Kaohsiung rapid transit
324.	Shin Zu Shing Co., Ltd. V Shu-Lin Factory	Factory	373.	Kaohsiung Rapid Transit Corp.	Kaohsiung rapid transit
325.	Changhua Pou Chen Group	Factory	374.	Kaohsiung Rapid Transit Corp. (Generator Contract)	Kaohsiung rapid transit
326.	Tonnie Cosmetics Co., Ltd.	Factory	375.	Kaohsiung Rapid Transit Corp. - Operation Control Center	Kaohsiung rapid transit
327.	TECO Electric & Machinery Co. Ltd. - Jiangxi Factory Relocation Project	Factory	376.	Kaohsiung Rapid Transit Corp. V Ta-Liao Depot Busway Replacement Project	Kaohsiung rapid transit
328.	TECO - Qingdao Compressor Factory Construction Project	Factory	377.	Motor Control Panel Copper Busway Procurement (City Government) MRT Project, City Hall Station	City Hall MRT Station
329.	TECO - Qingdao Compressor Factory Busway Connector Additional Project	Factory			
330.	Raheja Mindspace (India Project)	Factory			
331.	Depo Auto Parts Ind. Co., Ltd. V Hsin-Ying Injection Plant Construction Project	Factory			
332.	Jenn Feng Industrial Co., Ltd., Ping-Chen Factory - Voltage Adjustment and Partial Construction Project	Factory			
333.	Jenn Feng Industrial Co., Ltd., Ping-Chen Factory - Voltage Adjustment and Partial Construction Project	Factory			
334.	Lung-Te Public Factory - Electric Room Firefighting Instrumentation Improvement Project	Factory			





# Projects Reference List

No.	Project	Industry Type	No.	Project	Industry Type
378.	Taoyuan International Airport Access MRT System Construction Plan - CU02 Construction Bid V Plumbing & Electrical Work Project	Airport Access MRT System	420.	Central Taiwan Park, Sewage Treatment Plant	Sewage Treatment Plant
379.	Taoyuan International Airport Access MRT System Construction Plan - CU03 Construction Bid V Plumbing & Electrical Work Project	Airport Access MRT System	421.	Taipei Gymnasium (Air-conditioning Works)	Sports Stadium
380.	Taoyuan International Airport Access MRT System Construction Plan V CE02 Construction Bid V Plumbing & Electrical Work Project	Airport Access MRT System	422.	Taipei Gymnasium (Plumbing & Electrical Works)	Sports Stadium
381.	Taipei Station V CL308/363/365/368/373 Bid	HSR Station	423.	Taipei Stadium (Hsin-Jui-Cheng)	Sports Stadium
382.	Sung-Shan Station - Civil Engineering and Electrical Engineering Project; Tunnel Section from Kun-Yang Street to Keelung Road (Plumbing & Electrical Work and Joint Tender on Additional Busway System)	Sung-Shan Station	424.	Pan-Chiao Neo Sky Dome - New Construction Project	Sports Stadium
383.	Hsuehshan Tunnel - Busway Replacement Project	Tunnel	425.	Pan-Chiao Neo Sky Dome - New Construction Project (435A Additional Works)	Sports Stadium
384.	Hsuehshan Tunnel - Busway Replacement Project (2)	Tunnel	426.	MOEA Nan-Kang Exhibition Hall - New Construction Project	Exhibition Hall
385.	Hsuehshan Tunnel - Busway Replacement Project (3)	Tunnel	427.	Lo-Shan Radar Station	Radar Station
386.	Chiang Kai-shek International Airport	Aviation	428.	Taipei Station Underground Shopping Street V High- & Low-voltage Electrical Equipment	Shopping Mall
387.	Evergreen Aviation Technology Corp., Hangar No. 2	Aviation	429.	B&Q Nan-Kan Shopping Mall - New Construction Project (Electrical Works)	Shopping Mall
388.	Far Glory Air Cargo Terminal	Aviation	430.	Fubon A10 Xinyi District Shopping Mall & Hotel - New Construction Project	Shopping Mall
389.	Chiang Kai-shek International Airport, Radar Station	Aviation	431.	Pingtung County Mi-Li Community ES Extra-high Voltage Construction Project	Substation
390.	Civil Aeronautics Administration, North Terminal	Aviation	432.	Kaohsiung Extra-high Voltage ES Construction Project	Substation
391.	Aerospace Industrial Development Corp., Hangar No. 6	Aviation	433.	Yu-Ching-Tang	Cement Plant
392.	Ho-Hsin Lotus Hill	Residential Building	434.	Indonesian Paper Mill	Paper Mill
393.	Zhishan Garden	Residential Building	435.	Lealea Group - Additional Project	Textile
394.	Lu-Kuang 2nd Village	Residential Building	436.	Nankang Software Park - Phase 3 New Construction Project	High Tech Factory
395.	Galaxy Aqua City	Residential Building	437.	Nankang Software Park - Phase 3 Busway System Construction Project	High Tech Factory
396.	A Date in Tamsui	Residential Building	438.	Pu-Li Lingyun Mountain Temple V Central Hall Construction Project (Electrical Engineering System)	Temple
397.	Star of Lih Pao	Residential Building	439.	AF-AUFN Program - Operation Zone Renovation Works	Military Barrack
398.	Tainan County Tang-Shan Village - New Construction Project	Residential Building	440.	Army Hua-Shan Barrack	Military Barrack
399.	World Garden V Bridge Up To Zenith Construction Project	Residential Building	441.	Taiwan Yen-Wan Skill Training Institute	Jailhouse
400.	Lih Pao Construction Co., Ltd. V Pan-Chiao City New Pan-Chiao Section, 30-story Residential & Commercial Building Construction Project	Residential Building	442.	Hsinchu City Funeral Parlor & Funeral Hall Construction Project V Plumbing & Electrical Engineering Project	Funeral Parlor
401.	Bao-Chan Construction Co., Ltd. V (Shen-Keng) New Construction Project	Residential Building	443.	Ta-Chia Township First Public Retail Market Renovation & Repair Plan Project	Market
402.	Lan-Hai Phase 1 New Construction Project	Residential Building	444.	Shui-Yuan Market Repair & Renovation Project	Market
403.	Huang Hsiang Construction Corporation V 20-story Building on Sung-Te Road Project	Residential Building	445.	Feng-Shan RT-MART, Feng-Shan City, Kaohsiung County - New Construction Project	Shopping Mall
404.	Kaohsiung City Government, Economic & Trade Square	Residential Building	446.	Tou-Fan RT-MART Factory Building - New Construction Project	Shopping Mall
405.	Lien-Chu-Fang-Ting	Residential Building	447.	Da Dong Art Center, Feng-Shan City	Art Center
406.	Lih Pao Construction Co., Ltd. V Pan-Chiao City New Pan-Chiao Section, 30-story Residential & Commercial Building Construction Project - Additional 2000A	Residential Building	448.	Da Dong Art Center, Feng-Shan City V Phase 2	Art Center
407.	Lung-Huang Development Co., Ltd. - Sanchung City Yung-Te Section Construction Project	Residential Building	449.	Huallian Creative Culture & Industrial Park V Air-conditioning & Electrical Equipment Project	Art Center
408.	Xinyi Residential Building	Residential Building	450.	Farglory Land Development Co., Ltd. - O3 Financial Center Construction Project	Financial Center
409.	Yueh-Sheng Building - New Construction Project	Residential Building	451.	Jia-Lin Junior High School, New Taipei City V School Campus Construction Project	School
410.	Chung Yuet Group V New Construction Project of 12 land lots located on No. 256, Yang-Chou Section, Lu-Chu Hsiang	Residential Building	452.	Kuang-Yang Science Park (Ching-Tien Factory) - New Construction Project	Electronic Industry
411.	Huaku Development Co., Ltd. V Jui-Kuang Section	Residential Building	453.	Sunworld Dynasty Taipei Hotel - E & M System Improvement & Renewal Project (Electrical Engineering Works)	Bank, hotel, department store
412.	Farglory Land Development Co., Ltd. - M61 Project	Residential Building	454.	Songshan Tobacco Factory - Cultural Park BOT Program (Electrical Engineering Works)	Bank, hotel, department store
413.	Kuan-Tu Star of the North	Residential Building	455.	Acron Technology Corporation - Factory Building Construction Project	Factory Building
414.	MRT Xindian Line Depot - Joint Development Project (Mei-Ho City)	Residential & Commercial Building			
415.	Kung-Hsieh Village, Feng-Shan District, Kaohsiung County - New Construction Project	Military Dependents Village			
416.	Ilan County Government Administration Center - Military Dependents Village Construction Project	Military Dependents Village			
417.	Southern Taiwan Science Park, Phase 2 Site Sewage Treatment Plant	Sewage Treatment Plant			
418.	Peace Island Sewage Treatment Plant, Phase 1 New Construction Project	Sewage Treatment Plant			
419.	Peace Island Sewage Treatment Plant, Phase 1 New Construction Project (Additional Works)	Sewage Treatment Plant			