

HOLLOW SHAFT END CARRIAGE

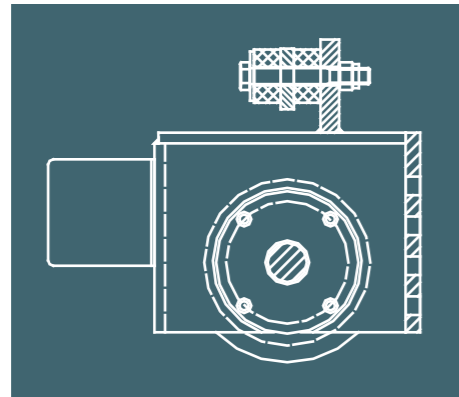

End Carriage

Crane Traveling Mechanism

Catalogue

HSE-HSB-HSW-OGE-OGB-OGW Series

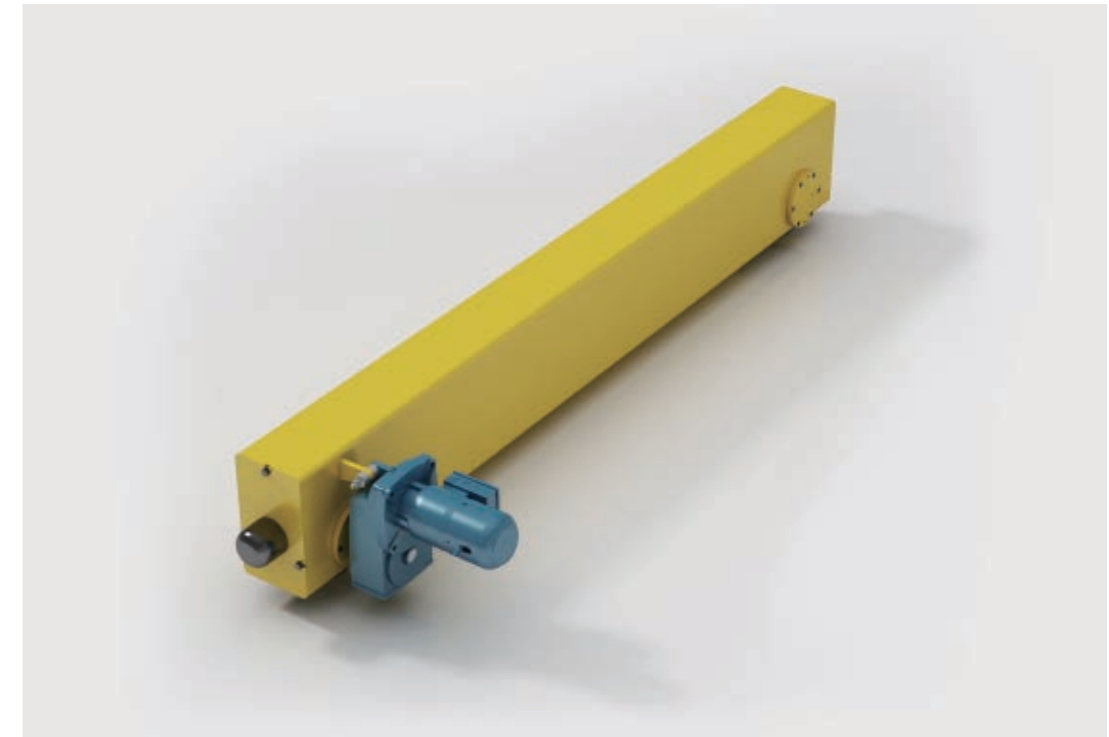

H S W 160 - D25

W: wheel set
B: wheel block
E: end carriage

wheel diameter

D: double girder

end carriage length

Hollow Shaft End Carriage

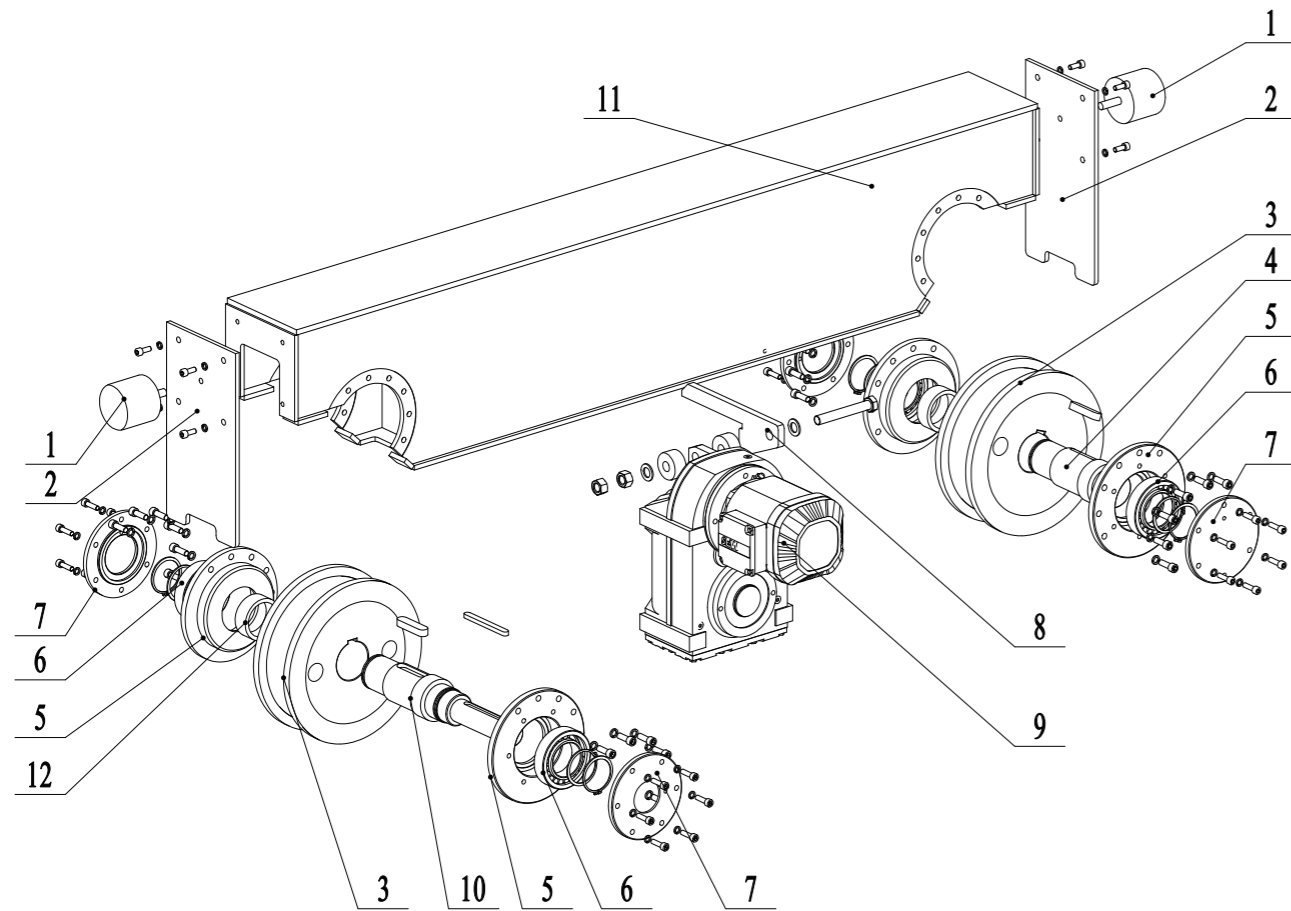

NO.	Description	Qty
1	Buffer	2
2	Stopper Plate	2
3	Wheel	2
4	Idle Wheel Shaft	1
5	Bearing Support	4
6	Bearing	4
7	Bearing House	4
8	Mounting Plate for Motor	1
9	Geared Motor	1
10	Drive Wheel Shaft	1
11	Structure	1
12	Spacer	2

HSE Hollow Shaft End Carriage

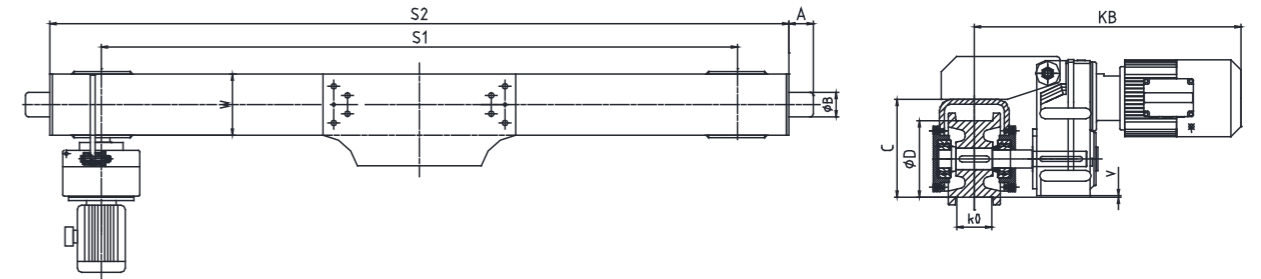

Model	ΦD (mm)	S1 (mm)	S2 (mm)	A (mm)	ΦB (mm)	W (mm)	C (mm)	K0 (mm)
HSE125-15	125	1500	1736	50	60	150	212.5	60
HSE125-20		2000	2336					
HSE125-25		2500	2836					
HSE125-30		3000	3336					
HSE125-35		3500	3836					
HSE160-15	160	1500	1766	80	80	150	270	65
HSE160-20		2000	2266					
HSE160-25		2500	2766					
HSE160-30		3000	3266					
HSE160-35		3500	3766					
HSE200-15	200	1500	1820	80	80	200	325	75
HSE200-20		2000	2320					
HSE200-25		2500	2820					
HSE200-30		3000	3320					
HSE200-35		3500	3820					
HSE250-15	250	1500	1870	90	100	200	375	80
HSE250-20		2000	2370					
HSE250-25		2500	2870					
HSE250-30		3000	3370					
HSE250-35		3500	3870					
HSE320-25	320	2500	2940	90	100	230	435	80
HSE320-30		3000	3440					
HSE320-35		3500	3940					
HSE320-40		4000	4440					
HSE320-45		4500	4940					
HSE400-25	400	2500	3020	100	120	260	540	85
HSE400-30		3000	3520					
HSE400-35		3500	4020					
HSE400-40		4000	4520					
HSE400-45		4500	5020					

HSB Hollow Shaft Wheel Block

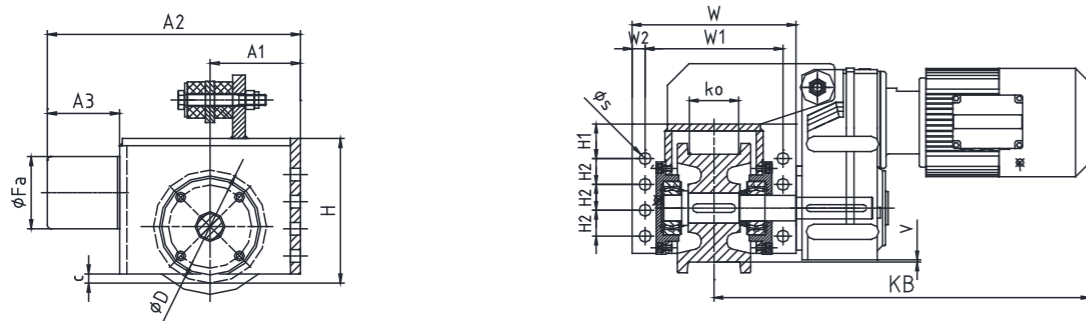

Model	ΦD (mm)	A1 (mm)	A2 (mm)	A3 (mm)	C (mm)	Fa (mm)	W (mm)	W1 (mm)	W2 (mm)	H (mm)	H1 (mm)	H2 (mm)	ΦS (mm)	K0 (mm)
HSB125	125	100	250	50	10	60	190	160	15	160	40	30	14	60
HSB160	160	120	315	80	20	80	220	190	15	200	50	35	14	65
HSB200	200	145	360	80	30	80	260	210	25	250	50	45	18	75
HSB250	250	180	440	90	30	100	280	230	25	290	75	50	18	80
HSB320	320	225	530	90	35	100	320	260	30	385	75	75	22	80
HSB400	400	290	650	100	40	120	370	310	30	480	100	100	22	85
HSB500	500	360	770	100	70	120	440	360	40	600	130	120	26	90
HSB630	630	395	880	100	95	120	450	370	40	745	140	140	32	90

Model	Tread Width (mm)	Output Shaft with keyway (mm)	NORD Motor	KB (mm)	V (mm)	SEW Motor	KB (mm)	V (mm)
HSB125	60	Ø25×89	SK0182-0.25kW	454	8	FA27-0.25kW	436	2.5
HSB125	60	Ø25×89	SK0182-0.37kW	454	8	FA27-0.37kW	461	2.5
HSB125	60	Ø25×89	SK0182-0.55kW	502	8	FA27-0.55kW	486	2.5
HSB160	65	Ø30×105	SK1282-0.37kW	517	5	FA37-0.37kW	491	4
HSB160	65	Ø30×105	SK1282-0.55kW	548	5	FA37-0.55kW	516	4
HSB160	65	Ø30×105	SK1282-0.75kW	548	5	FA37-0.75kW	538	4
HSB200	75	Ø30×105	SK1282-0.55kW	558	25	FA37-0.55kW	526	24
HSB200	75	Ø30×105	SK1282-0.75kW	558	25	FA37-0.75kW	548	24
HSB200	75	Ø35×132	SK2282-0.75kW	570	10	FA47-0.75kW	571	23
HSB200	75	Ø35×132	SK2282-1.1kW	622	10	FA47-1.1kW	602	23
HSB200	75	Ø35×132	SK2282-1.5kW	622	10	FA47-1.5kW	618	23
HSB250	80	Ø35×132	SK2282-0.75kW	583	35	FA47-0.75kW	584	48
HSB250	80	Ø35×132	SK2282-1.1kW	635	35	FA47-1.1kW	615	48
HSB250	80	Ø35×132	SK2282-1.5kW	635	35	FA47-1.5kW	631	48
HSB250	80	Ø40×156	SK3282-1.1kW	655	19	FA67-1.1kW	636	28
HSB250	80	Ø40×156	SK3282-1.5kW	655	19	FA67-1.5kW	650	28
HSB250	80	Ø40×156	SK3282-2.2kW	701	19	FA67-2.2kW	670	28
HSB320	80	Ø40×156	SK3282-1.1kW	647	54	FA67-1.1kW	628	63
HSB320	80	Ø40×156	SK3282-1.5kW	647	54	FA67-1.5kW	642	63
HSB320	80	Ø50×183	SK4282-1.5kW	665	37	FA77-1.5kW	667	39
HSB320	80	Ø50×183	SK4282-2.2kW	711	37	FA77-2.2kW	687	39
HSB320	80	Ø50×183	SK4282-3kW	711	37	FA77-3kW	717	39

*If K0<Applied rail, please contact us

HSSB Hollow Shaft End Carriage (GGG70 Wheel Material)

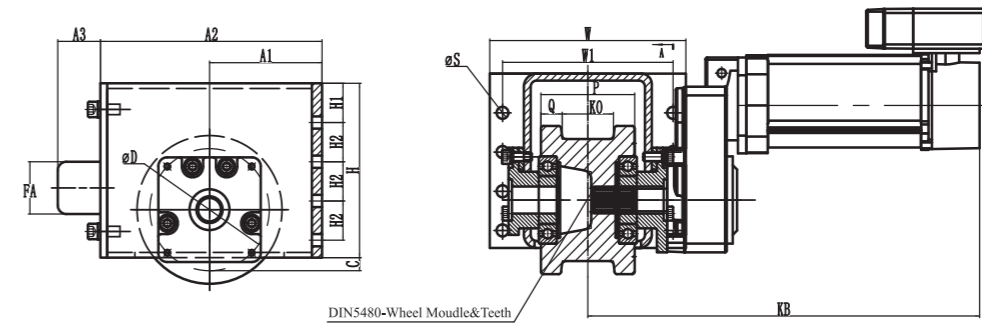

ΦD (mm)	A1 (mm)	A2 (mm)	A3 (mm)	C (mm)	Fa (mm)	W (mm)	W1 (mm)	W2 (mm)	H (mm)	H1 (mm)	H2 (mm)	S (mm)	Q (mm)	K0 (mm)	P (mm)	KB (mm)	Weight (kg)
110	122	240	50	15	60	230	200	15	200	45	45	14	18.5	60	110	415.5	26
140	133	260	50	15	60	230	200	25	200	45	45	14	25	60	110	459.5	32
160	140	273	80	15	80	260	210	25	200	45	45	18	19	70	110	466.5	35
200	161	307	80	15	80	310	260	25	250	65	50	18	20	80	130	488	61
250	191	367	90	15	100	310	260	25	300	70	65	18	25	90	145	560	87

Wheel Mouldle&Teeth	Wheel Tread Dia (mm)	Speed (m/min)	Motor type	Power (kW)
DIN5480-N22×1.25×16×9H	110	32	NGG3	0.3
DIN5480-N30×1.5×18×9H	140	32	NGG3	0.37
DIN5480-N30×1.5×18×9H	160	32	NGG3	0.65
DIN5480-N30×1.5×18×9H	200	32	NGG4	1.1
DIN5480-N45×2×21×9H	250	32	NGG4	2.2
DIN5480-N45×2×21×9H	315	32	NGG4	2.2
DIN5480-N55×2×26×9H	400	32	NGG5	3
DIN5480-N55×2×26×9H	500	32	NGG5	3

Classification of Mechanisms Acc. With F.E.M. (ISO)									
Load Spectrum	Definition	Average operating time per day in hours							
		≤0.25	≤0.5	≤1	≤2	≤4	≤8	≤16	> 16
Light	Mechanisms, or parts thereof, usually subject to light loads and occasional maximum loads	—	1Dm (M1)	1Cm (M2)	1Bm (M3)	1Am (M4)	2m (M5)	3m (M6)	4m (M7)
Medium	Mechanisms, or parts thereof, usually subject to light loads, but with a higher incidence of maximum loads	1Dm (M1)	1Cm (M2)	1Bm (M3)	1Am (M4)	2m (M5)	3m (M6)	4m (M7)	5m (M8)
Heavy	Mechanisms, or parts thereof, usually subject to medium loads, and frequently to maximum loads	1Cm (M2)	1Bm (M3)	1Am (M4)	2m (M5)	3m (M6)	4m (M7)	5m (M8)	—
Very Heavy	Mechanisms, or parts thereof, usually subject to maximum or almost maximum loads	1Bm (M3)	1Am (M4)	2m (M5)	3m (M6)	4m (M7)	5m (M8)	—	—

HSE Bogie for Overhead Crane

HSE200 - XX × 2 - OC - YY

Wheel diameter
Length of end carriage
Length of Joint Beam
For overhead crane

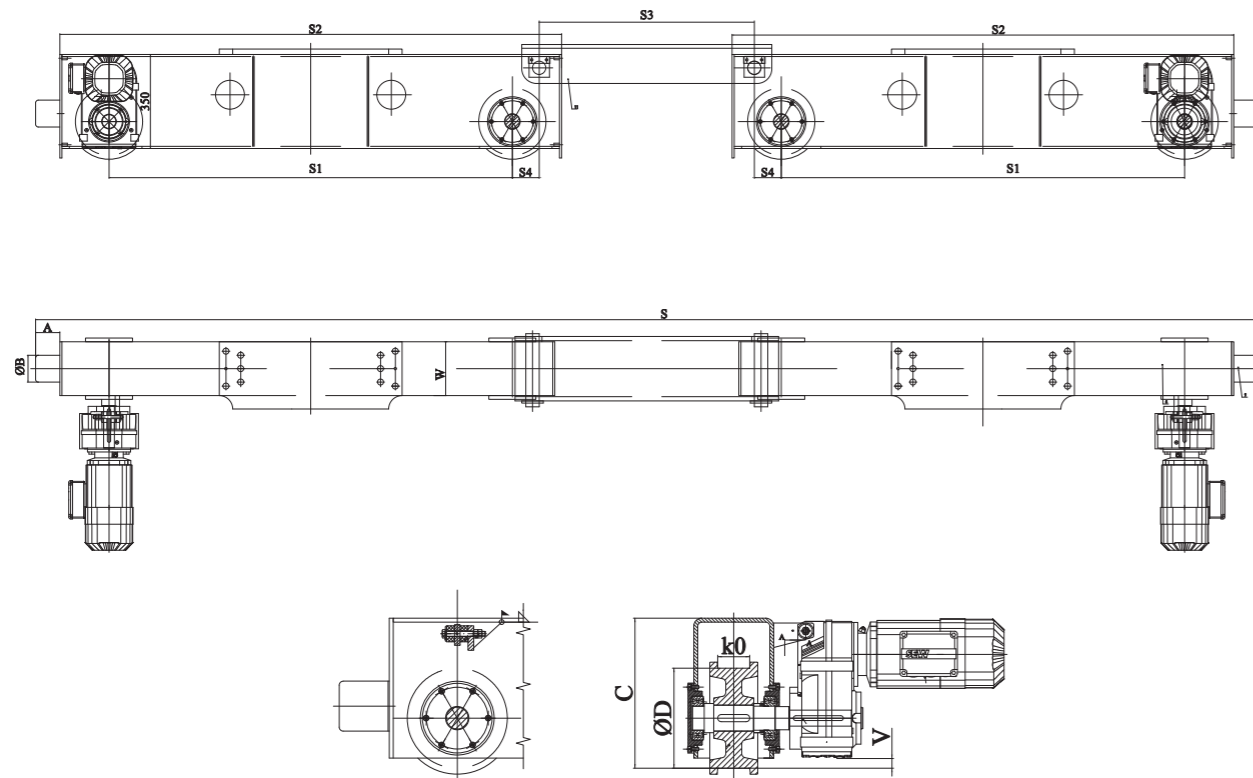

HSE Bogie for Gantry Crane

HSE200 - XX × 2 - GC - YY

Wheel diameter
Length of end carriage
Length of End Beam
For gantry crane

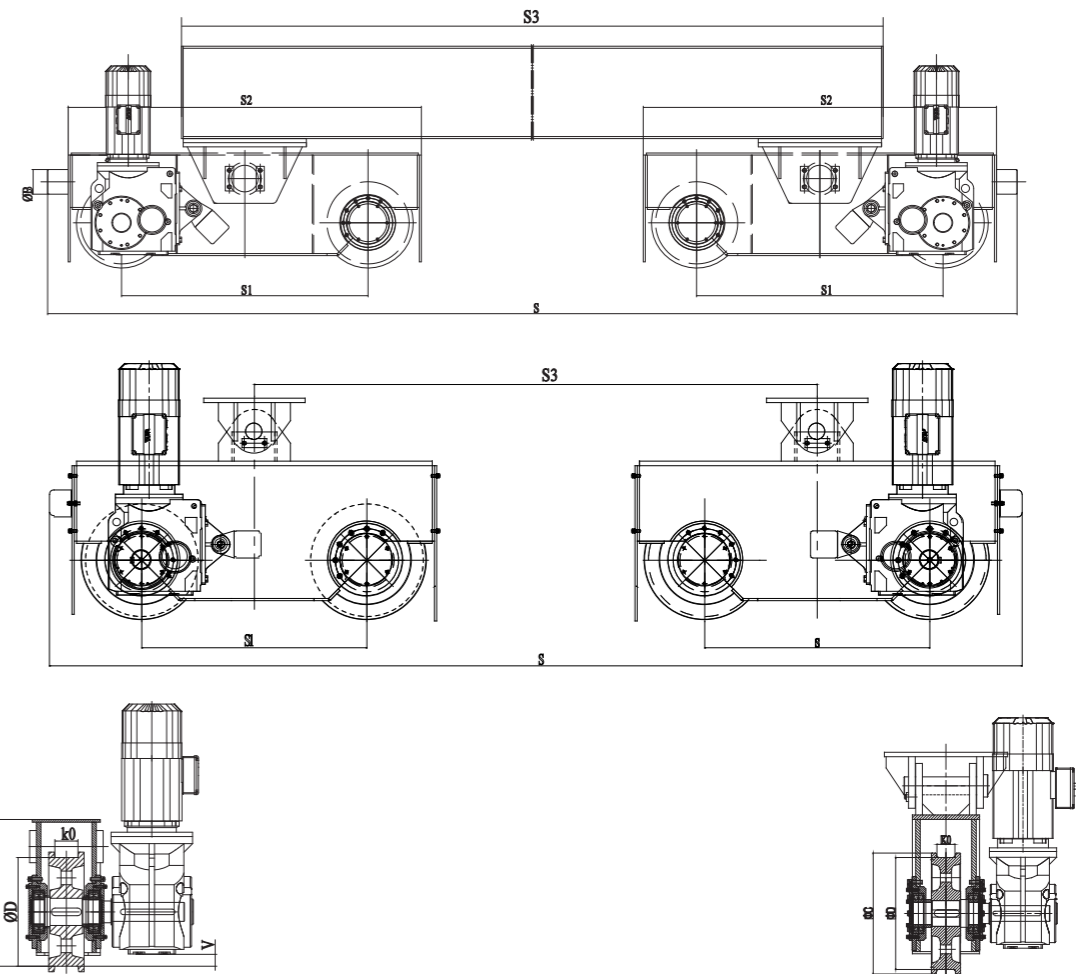

Model Name	Wheel Size (mm)	Length of Boogie (S1)	Length of Joint Beam (S3)	Speed (m/min)	No.of Gear Motor
HSE200-XX×2-OCYY	200mm * 8unit	1m, 1.5m, 2m, 2.5m, 3m	1m, 1.5m, 2m, 2.5m, 3m	20, 32, 40	2, 4
HSE250-XX×2-OCYY	250mm * 8unit	1m, 1.5m, 2m, 2.5m, 3m	1m, 1.5m, 2m, 2.5m, 3m	20, 32, 40	2, 4
HSE320-XX×2-OCYY	320mm * 8unit	1.5m, 2m, 2.5m, 3m, 3.5m	1m, 1.5m, 2m, 2.5m, 3m	20, 32, 40	2, 4
HSE400-XX×2-OCYY	400mm * 8unit	1.5m, 2m, 2.5m, 3m, 3.5m	1.5m, 2m, 2.5m, 3m, 3.5m	20, 32, 40	2, 4
HSE500-XX×2-OCYY	500mm * 8unit	2m, 2.5m, 3m, 3.5m, 4m	1.5m, 2m, 2.5m, 3m, 3.5m	20, 32, 40	2, 4
HSE630-XX×2-OCYY	630mm * 8unit	2m, 2.5m, 3m, 3.5m, 4m	1.5m, 2m, 2.5m, 3m, 3.5m	20, 32, 40	2, 4

Model Name	Wheel Size (mm)	Length of Boogie(S1)	Length of Joint Beam(S3)	Speed (m/min)	No.of Gear Motor
HSE200-XX×2-GCYY	200mm * 8unit	0.8m, 1m, 1.2m	3m, 4m, 5m, 6m, 7m	20, 32, 40	2, 4
HSE250-XX×2-GCYY	250mm * 8unit	0.8m, 1m, 1.2m	3m, 4m, 5m, 6m, 7m	20, 32, 40	2, 4
HSE320-XX×2-GCYY	320mm * 8unit	1m, 1.2m, 1.5m	3m, 4m, 5m, 6m, 7m	20, 32, 40	2, 4
HSE400-XX×2-GCYY	400mm * 8unit	1.2m, 1.5m, 2m	3m, 4m, 5m, 6m, 7m	20, 32, 40	2, 4
HSE500-XX×2-GCYY	500mm * 8unit	1.2m, 1.5m, 2m, 2.5m	3m, 4m, 5m, 6m, 7m	20, 32, 40	2, 4
HSE630-XX×2-GCYY	630mm * 8unit	1.5m, 2m, 2.5m	3m, 4m, 5m, 6m, 7m	20, 32, 40	2, 4

Wheel Sets for Hollow Shaft End Carriage
HSW Series

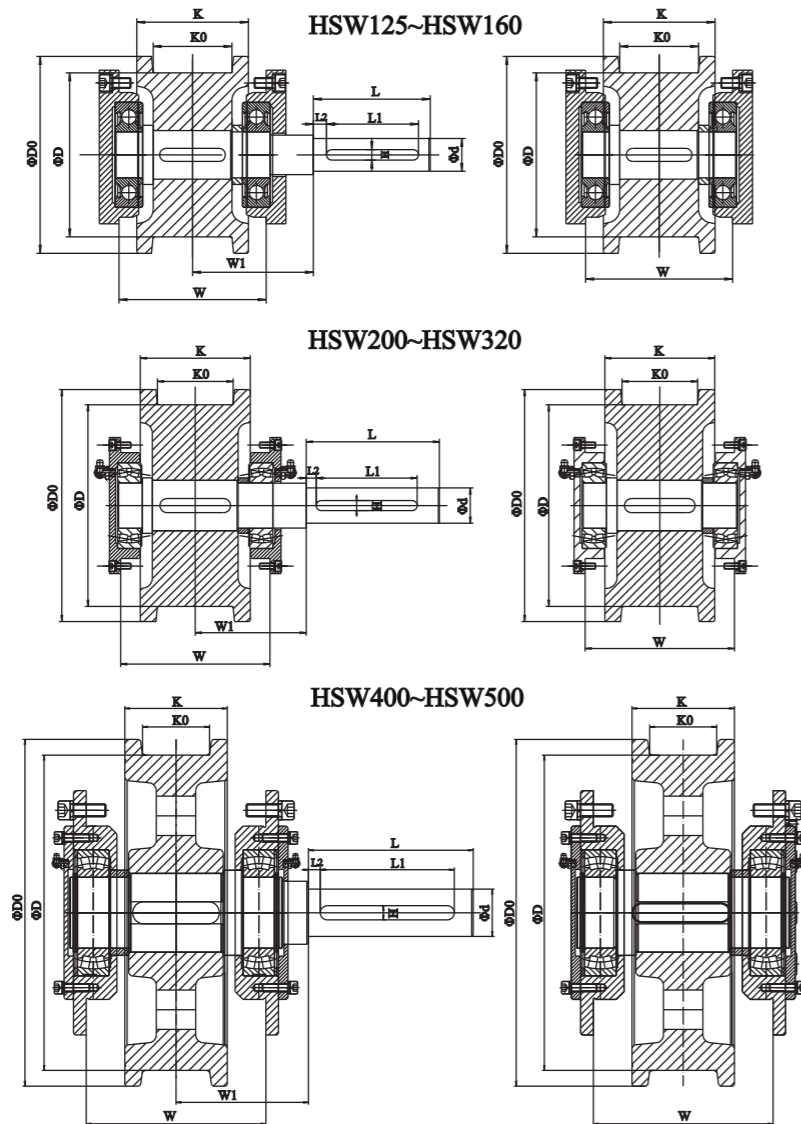

OPEN GEAR END CARRIAGE

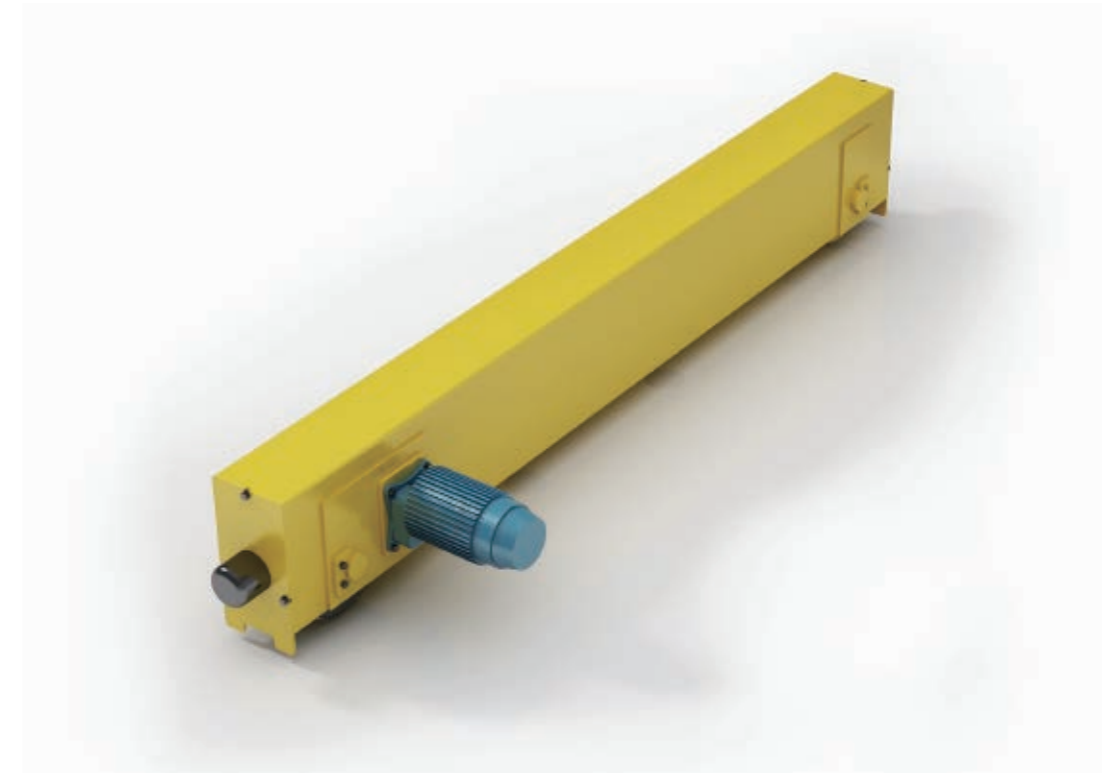

Wheel Size	Φ125	Φ160	Φ200	Φ250	Φ320	Φ400	Φ500
ΦD0	150	187	230	280	360	440	540
Φd	25	30	35	40	50	60	70
L	89	105	132	156	183	209	270
L1	10	10	10	10	20	15	15
L2	70	80	100	120	140	170	220
H	8	8	10	12	14	18	20
K0	60	65	75	80	80	85	90
K	85	99	109	120	120	130	140
W	112	140	148	168	178	228	268
W1	92	105	120	133	125	168	194

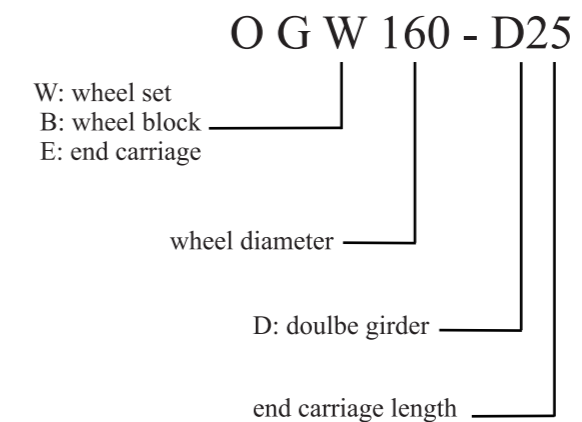

NT Motor for Open Gear End Carriage
NT Series

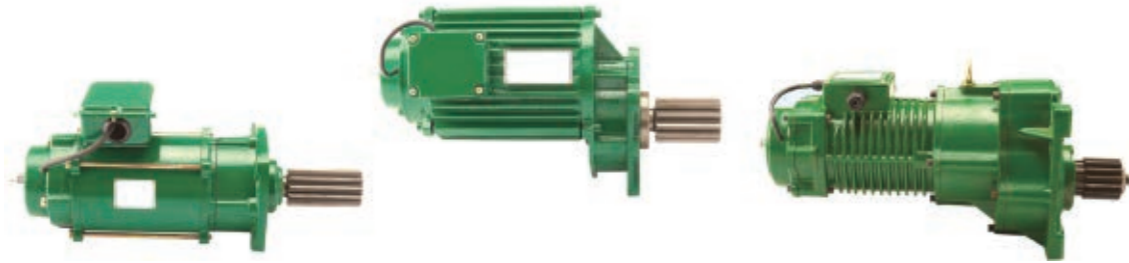

Gear Motor Model	Power	Pole No.	Moudle	Ratio	Speed		Voltage
					50Hz (r/min)	60Hz (r/min)	
NT-030	0.25kW	4P	M3 M3.5 M4	10:1	133	176	220V-440V 50Hz/60Hz 3Phase
NT-050	0.4kW	4P	M3 M3.5 M4	8.5:1	176	210	
NT-100	0.75kW	4P	M3 M3.5 M4 M5	7.7:1	189	228	
NT-150	1.1kW	4P	M3.5 M4 M5	13:1	112	135	
NT-200	1.5kW	4P	M3.5 M4 M5 M6	16:1	92	110	
NT-300	2.2kW	4P	M4 M5 M6	16:1	92	110	
NT-500	3.75kW	4P	M5 M6 M7	16:1	92	110	

End Carriage Spare Parts - Hand Seal Retainer

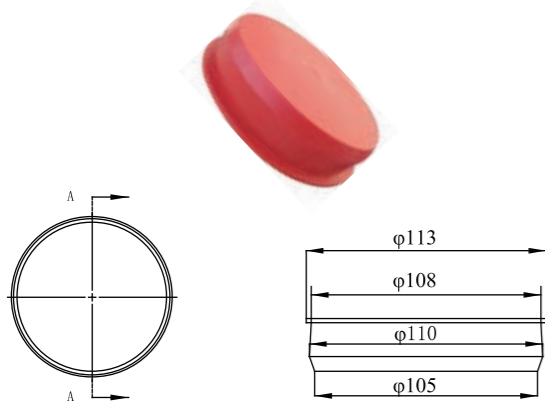

End Carriage Spare Parts - Buffer

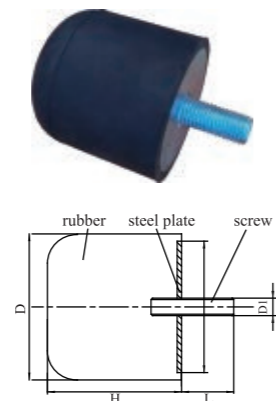

Model	Dimensions (mm)		
	Height×φ	D1	L
B60	50×60	50	M12*25
B80	80×80	70	M12*25
B100	90×100	90	M12*25
B120	100×120	110	M12*25
B160	160×160	150	M12*25
B200	200×200	190	M12*25

Wheel Dia.(mm)	Group classification of Mechanism(FEM)	Applied Rail Head Width(mm)	Crane Travel Speed(m/min)										
			10	12.5	16	20	25	32	40	50	63	80	100
110	M1-M4	35	28.31	27.47	26.63	26.91	24.66	23.54	21.86	20.46	19.34	17.66	16.26
		40	32.35	31.39	30.43	30.75	28.19	26.91	24.98	23.38	22.10	20.18	18.58
		45	36.40	35.32	34.23	34.59	31.71	30.27	28.11	26.31	24.86	22.70	20.90
	M5	35	25.28	24.52	23.77	24.02	22.02	21.02	19.52	18.27	17.27	15.77	14.51
		40	28.89	28.03	27.17	27.46	25.17	24.02	22.31	20.88	19.73	18.02	16.59
		45	32.50	31.53	30.57	30.89	28.31	27.03	25.10	23.49	22.20	20.27	18.66
125	M1-M4	35	32.49	31.85	30.58	30.58	28.67	27.71	25.80	24.21	22.61	21.02	19.11
		40	37.13	36.40	34.94	34.94	32.76	31.67	29.48	27.66	25.84	24.02	21.84
		45	41.77	40.95	39.31	39.31	36.86	35.63	33.17	31.12	29.07	27.03	24.57
	M5	35	29.01	28.44	27.30	27.30	25.59	24.74	23.03	21.61	20.19	18.77	17.06
		40	33.15	32.50	31.20	31.20	29.25	28.28	26.33	24.70	23.08	21.45	19.50
		45	37.29	36.56	35.10	35.10	32.91	31.81	29.62	27.79	25.96	24.13	21.94
140	M1-M4	40	41.99	41.18	39.95	39.14	37.51	36.28	34.25	32.21	30.17	28.13	25.68
		45	47.24	46.32	44.95	44.03	42.19	40.82	38.53	36.23	33.94	31.65	28.89
		50	52.49	51.47	49.94	48.92	46.88	45.35	42.81	40.26	37.71	35.16	32.10
	M5	40	37.49	36.76	35.67	34.94	33.49	32.40	30.58	28.76	26.94	25.12	22.93
		45	42.18	41.36	40.13	39.31	37.67	36.45	34.40	32.35	30.30	28.26	25.80
		50	46.87	45.96	44.59	43.68	41.86	40.50	38.22	35.95	33.67	31.40	28.67
160	M1-M4	40	49.39	47.99	46.59	45.66	43.80	42.40	40.54	38.67	36.34	34.01	31.22
		45	55.56	53.99	52.42	51.37	49.27	47.70	45.60	43.51	40.88	38.26	35.12
		50	61.73	59.99	58.24	57.08	54.75	53.00	50.67	48.34	45.43	42.52	39.02
	M5	40	44.10	42.85	41.60	40.77	39.10	37.86	36.19	34.53	32.45	30.37	27.87
		45	49.61	48.20	46.80	45.86	43.99	42.59	40.72	38.84	36.50	34.16	31.36
		50	55.12	53.56	52.00	50.96	48.88	47.32	45.24	43.16	40.56	37.96	34.84
200	M1-M4	45	71.42	69.45	67.49	65.52	63.55	61.59	59.62	57.00	53.73	50.45	47.17
		55	87.29	84.88	82.48	80.08	77.68	75.28	72.87	69.67	65.67	61.66	57.66
		65	103.16	100.32	97.48	94.64	91.80	88.96	86.12	82.34	77.60	72.87	68.14
	M5	45	63.77	62.01	60.26	58.50	56.75	54.99	53.24	50.90	47.97	45.05	42.12
		55	77.94	75.79	73.65	71.50	69.36	67.21	65.07	62.21	58.63	55.06	51.48
		65	92.11	89.57	87.04	84.50	81.97	79.43	76.90	73.52	69.29	65.07	60.84
250	M1-M4	45	90.91	89.27	86.81	84.36	81.90	79.44	76.99	74.53	71.25	67.16	63.06
		55	111.11	109.11	106.11	103.10	100.10	97.10	94.09	91.09	87.09	82.08	77.08
		65	131.31	128.95	125.40	121.85	118.30	114.75	111.20	107.65	102.92	97.01	91.09
	M5	45	81.17	79.71	77.51	75.32	73.13	70.93	68.74	66.54	63.62	59.96	56.31
		55	99.21	97.42	94.74	92.06	89.38	86.69	84.01	81.33	77.76	73.29	68.82
		65	117.24	115.13	111.96	108.79	105.63	102.46	99.29	96.12	91.89	86.61	81.33
320	M1-M4	45	118.46	116.36	114.27	111.12	107.98	104.83	101.69	98.54	95.40	91.20	85.96
		55	144.78	142.22	139.66	135.82	131.97	128.13	124.28	120.44	116.60	111.47	105.06
		65	171.11	168.08	165.05	160.51	155.97	151.42	146.88	142.34	137.80	131.74	124.17
	M5	45	105.77	103.90	102.02	99.22	96.41	93.60	90.79	87.98	85.18	81.43	76.75
		55	129.27	126.98	124.70	121.26	117.83	114.40	110.97	107.54	104.10	99.53	93.81
		65	152.78	150.07	147.37	143.31	139.26	135.20	131.14	127.09	123.03	117.62	110.86
400	M1-M4	55	182.58	180.98	177.78	174.57	169.77	164.96	160.16	155.36	150.55	145.75	137.74
		65	215.78	213.89	210.10	206.32	200.64	194.96	189.28	183.60	177.92	172.24	162.78
		75	248.98	246.79	242.42	238.06	231.50	224.95	218.40	211.85	205.30	198.74	187.82
	M5	55	163.02	161.59	158.73	155.87	151.58	147.29	143.00	138.71	134.42	130.13	122.98
		65	192.66	190.97	187.59	184.21	179.14	174.07	169.00	163.93	158.86	153.79	145.34
		75	222.30	220.35	216.45	212.55	206.70	200.85	195.00	189.15	183.30	177.45	167.70
500	M1-M4	65	272.09	269.72	267.36	262.63	257.89	250.80	243.70	236.60	229.50	222.40	215.31
		75	313.95	311.22	308.49	303.03	297.57	289.38	281.19	273.00	264.81	256.62	248.43
		85	355.81	352.72	349.62	343.43	337.25	327.96	318.68	309.40	300.12	290.84	281.55
	M5	65	242.94	240.83	238.71	234.49	230.26	223.93	217.59	211.25	204.91	198.58	192.24
		75	280.31	277.88	275.44	270.56	265.69	258.38	251.06	243.75	236.44	229.13	221.81
		85	317.69	314.93	312.16	306.64	301.11	292.83	284.54	276.25	267.96	259.68	251.39
630	M1-M4	65	348.80	342.83	339.85	336.87	330.91	324.95	316.00	307.06	298.12	289.17	280.23
		75	402.46	395.58	392.14	388.70	381.82	374.94	366.62	354.30	343.98	333.66	323.34
		85	456.12	448.32	444.42	440.52	432.73	424.93	413.23	401.54	389.84	378.15	366.45
	M5	65	311.42	306.10	303.44	300.78	295.45	290.13	282.15	274.16	266.18	258.19	250.20
		75	359.34	353.19	350.12	347.05	340.91	334.77	325.55	316.34	307.13	297.91	288.70
		85	407.25	400.29	396.81	393.32	386.36	379.40	369.96	358.52	348.08	337.63	327.19

Special Note: NANTE can offer 42Crmo forged steel material for heavy duty crane, and the wheel load is 1.3time more than S45C wheel material under the