

Wheel Sets for Hollow Shaft End Carriage
HSW Series

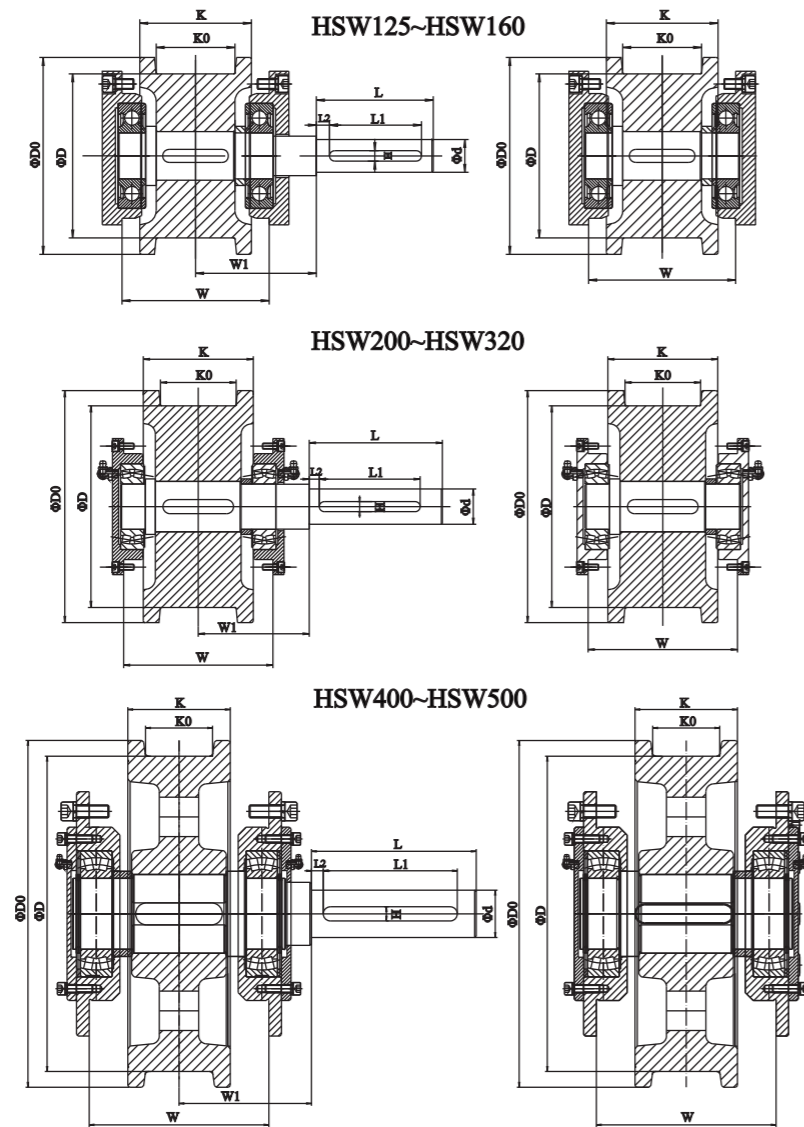

OPEN GEAR END CARRIAGE

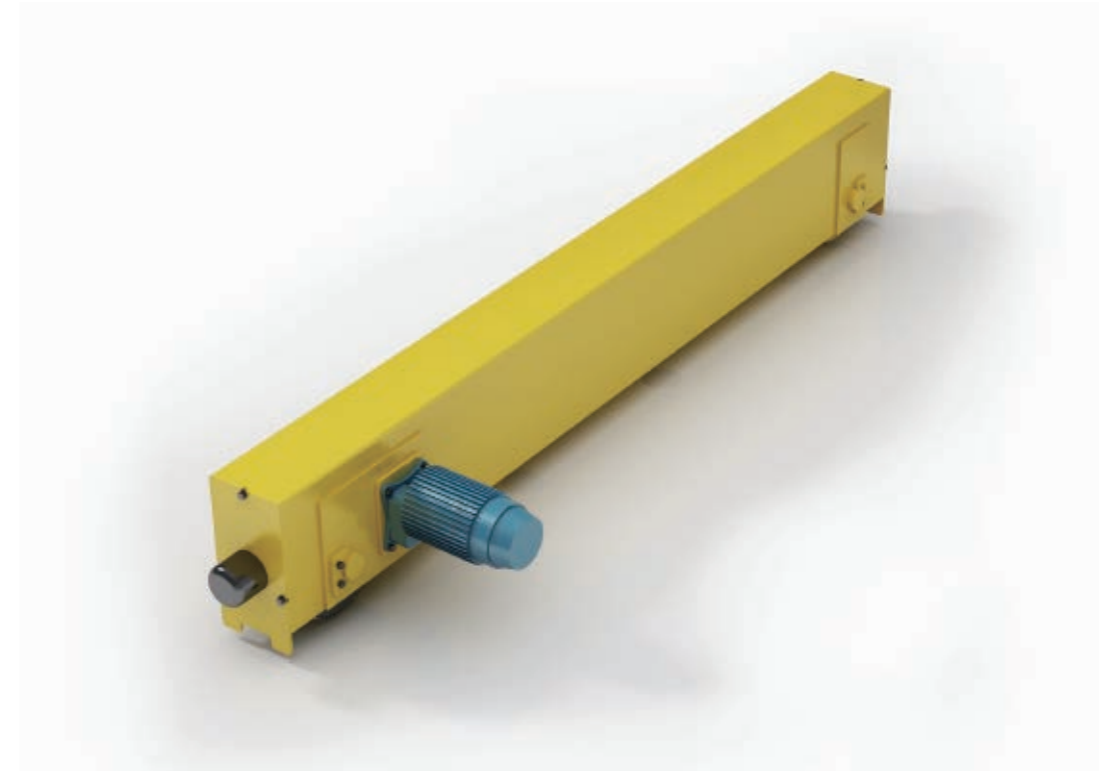

Wheel Size	Φ125	Φ160	Φ200	Φ250	Φ320	Φ400	Φ500
ΦD0	150	187	230	280	360	440	540
Φd	25	30	35	40	50	60	70
L	89	105	132	156	183	209	270
L1	10	10	10	10	20	15	15
L2	70	80	100	120	140	170	220
H	8	8	10	12	14	18	20
K0	60	65	75	80	80	85	90
K	85	99	109	120	120	130	140
W	112	140	148	168	178	228	268
W1	92	105	120	133	125	168	194

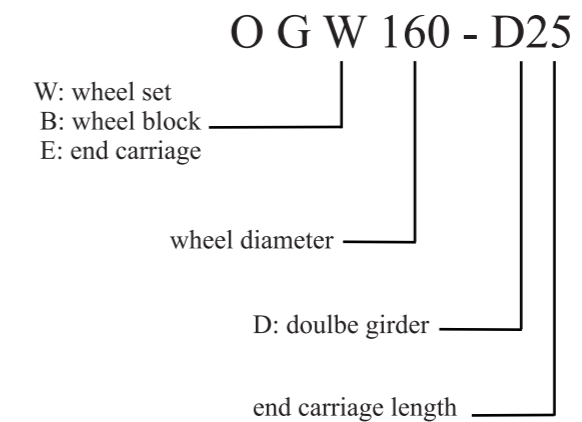

Open Gear End Carriage
OGE

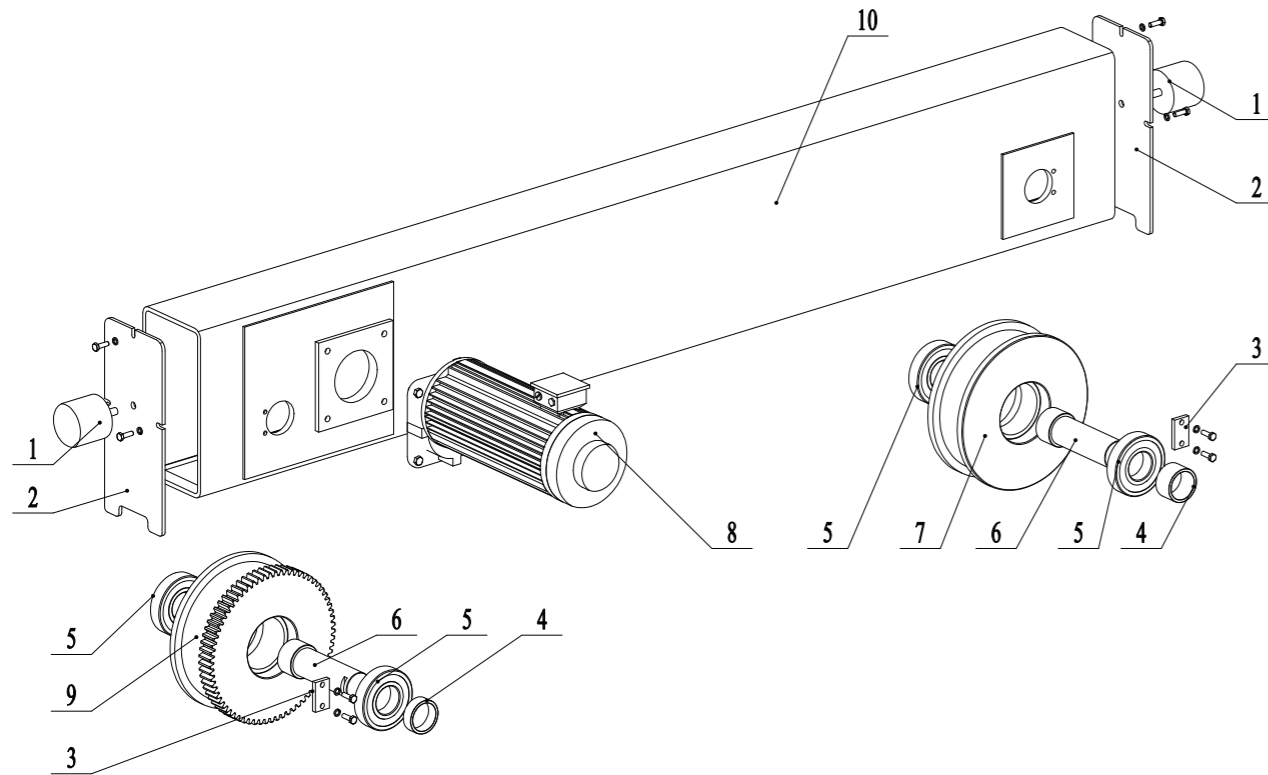

NO.	Description	Qty
1	Buffer	2
2	Stopper Plate	2
3	Snap-gauge	2
4	Spacer	2
5	Bearing	4
6	Wheel Shaft	2
7	Idle Wheel	1
8	Geared Motor	1
9	Drive Wheel	1
10	Structure	1

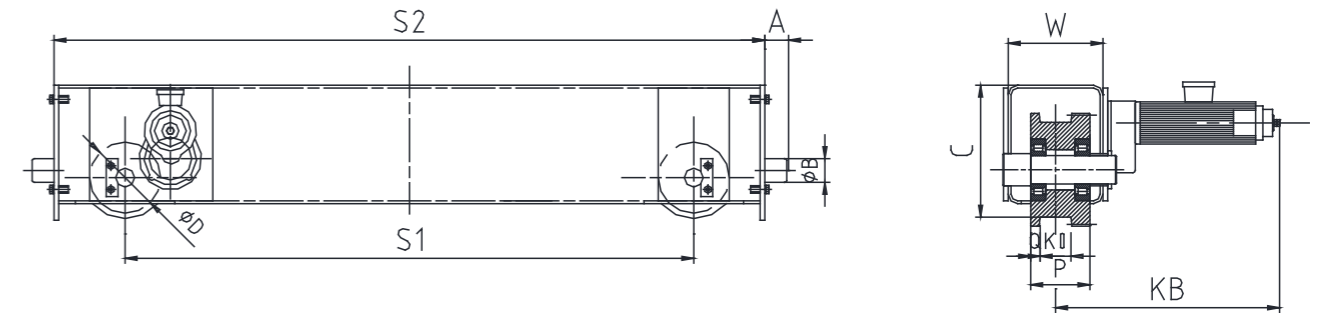

Model	ΦD (mm)	S1 (mm)	S2 (mm)	A (mm)	ΦB (mm)	W (mm)	C (mm)	K0 (mm)	Q (mm)	P (mm)
OGE120-12	120	1200	1616	50	60	150	215	60	10	92
OGE120-17		1700	2116							
OGE120-22		2200	2616							
OGE120-27		2700	3116							
OGE140-12		1200	1616							
OGE140-17	140	1700	2116	50	60	150	220	64	10	96
OGE140-22		2200	2616							
OGE140-27		2700	3116							
OGE168-12		1200	1676							
OGE168-17	168	1700	2176	80	80	150	279	64	12.5	104
OGE168-22		2200	2676							
OGE168-27		2700	3176							
OGE200-12		1200	1676							
OGE200-17	200	1700	2176	80	80	200	330	75	20	135
OGE200-22		2200	2676							
OGE200-27		2700	3176							
OGE200-32		3200	3676							
OGE250-16		1600	2196							
OGE250-21	250	2100	2696	90	100	200	385	80	20	140
OGE250-26		2600	3196							
OGE250-31		3100	3696							
OGE320-15		1500	2196							
OGE320-20	320	2000	2696	90	100	200	440	80	20	140
OGE320-25		2500	3196							
OGE320-30		3000	3696							
OGE320-35		3500	4196							

Open Gear Wheel Block
OGB

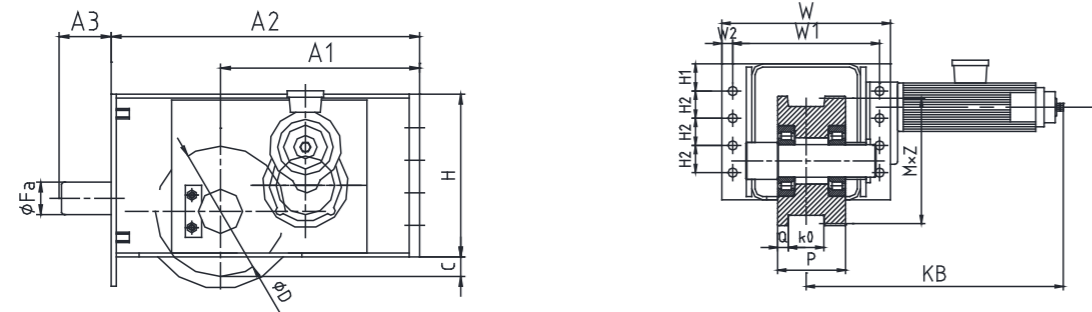

Model	ΦD (mm)	A1 (mm)	A2 (mm)	A3 (mm)	C (mm)	Fa (mm)	W (mm)	W1 (mm)	W2 (mm)	H (mm)	H1 (mm)	H2 (mm)	ΦS (mm)	k0 (mm)	P (mm)	M (mm)	N (mm)
OGB120	120	230	364	50	15	60	230	200	15	200	50	40	14	60	92	3	47
OGB140	140	240	434	50	20	60	230	200	15	200	50	40	14	64	96	3	54
OGB168	168	270	438	80	29	80	230	200	15	250	50	50	14	64	104	3	64
OGB200	200	305	473	80	30	80	300	260	20	300	60	60	18	75	135	3.5	66
OGB250	250	305	523	90	35	100	300	260	20	350	75	75	18	80	140	4	69
OGB320	320	390	618	90	40	100	330	270	30	400	85	85	22	80	140	4	69

Open Gear Suspension Crane End Carriager
SCE

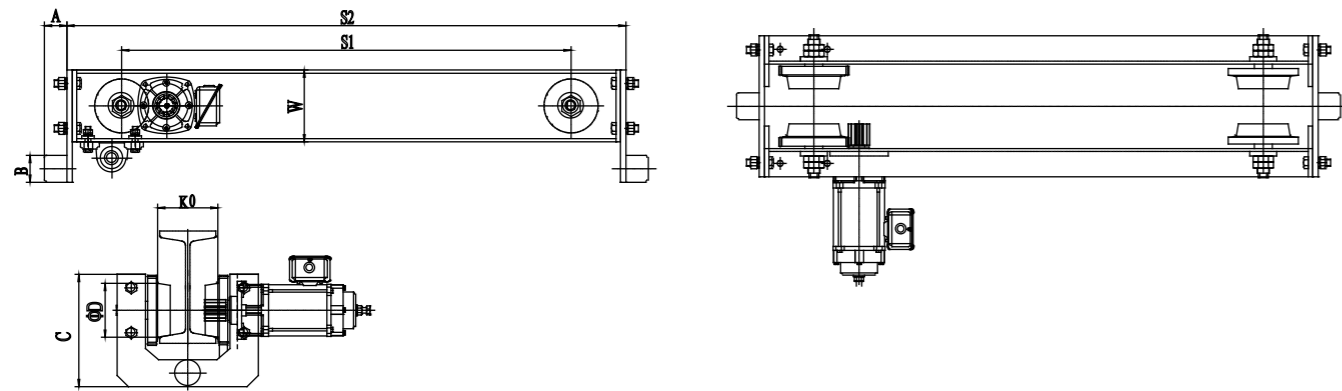

Model	ΦD (mm)	S1 (mm)	S2 (mm)	A (mm)	ΦB (mm)	W (mm)	C (mm)
SCE120-10		1000	1244				
SCE120-15	120	1500	1744	50	60	160	250
SCE120-20		2000	2244				
SCE150-10		1000	1350				
SCE150-15	150	1500	1850	80	80	200	300
SCE150-20		2000	2350				
SCE200-10		1000	1430				
SCE200-15	200	1500	1930	80	80	320	420
SCE200-20		2000	2430				

Wheel Sets for Open Gear End Carriage
OGW Series

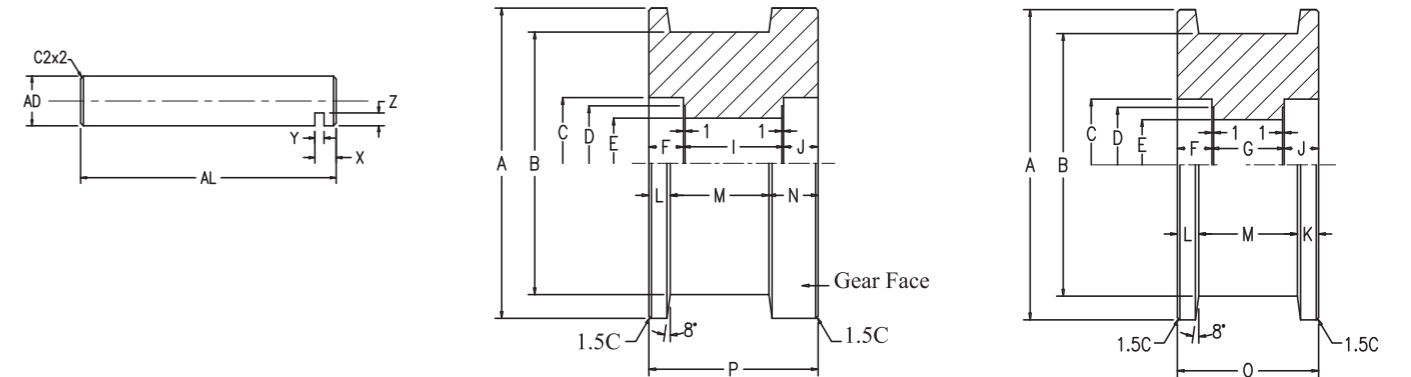

Wheel Size	Ø120	Ø140	Ø168	Ø200	Ø250	Ø320	Ø400	Ø500
A ± 0.1	Ø147	Ø168	Ø198	Ø238	Ø284	Ø355	Ø440	Ø540
B ± 0.1	Ø120	Ø140	Ø168	200	Ø250	Ø320	Ø400	Ø500
C	Ø80	Ø90	Ø110	Ø120	Ø130	Ø140	Ø160	Ø180
D	Ø70	Ø80	Ø90	Ø100	Ø110	Ø120	Ø140	Ø160
E	21	23	27	29	31	33	37	41
F	38	38	35	57	58	54	56	58
G	50	50	35	77	78	74	93	98
I	21	23	27(+15)	29	31	33	37	41
J	10	10	12.5	20	20	20	25	25
K	10	10	12.5	20	20	20	25	25
L	60	64	64	75	80	80	80	90
M	22	22	27.5	40	40	40	62	65
N	92	96	104	135	140	140	167	180
P	80	84	89	115	120	120	130	140
Gear Profile	M3T47	M3T54	M3T64	M3.5T66	M4T69	M5T69	M5T86	M6T88
Bearing	6207-2RS	6308-2RS	6310-2RS	6311-2RS	6312-2RS	6313-2RS	6315-2RS	6317-2RS
Bearing Size	Ø35×Ø80×21	Ø40×Ø90×23	Ø50×Ø110×27	Ø55×Ø120×29	Ø60×Ø130×31	Ø65×Ø140×33	Ø75×Ø160×37	Ø85×Ø180×41
AL	182	182	182	232	232	232	300	310
AC	Ø43	Ø48	Ø58	Ø68	Ø68	Ø78	Ø88	Ø98
AD	Ø35	Ø40	Ø50	Ø55	Ø60	Ø65	Ø75	Ø85
W	121	123	125.5	163.5	166	166	205	215
X	20	20	20	20	20	20	20	20
Y	10	10	10	10	10	10	10	10
Z	7.5	10	10	10	10	10	10	10

NT Motor for Open Gear End Carriage
NT Series

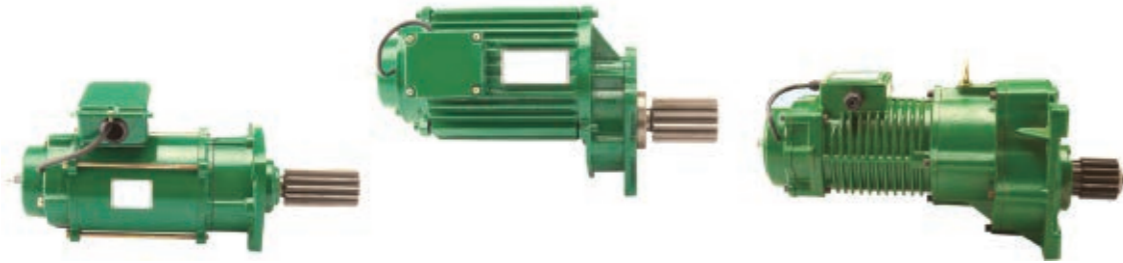

Gear Motor Model	Power	Pole No.	Mouldle	Ratio	Speed		Voltage
					50Hz (r/min)	60Hz (r/min)	
NT-030	0.25kW	4P	M3 M3.5 M4	10:1	133	176	220V-440V 50Hz/60Hz 3Phase
NT-050	0.4kW	4P	M3 M3.5 M4	8.5:1	176	210	
NT-100	0.75kW	4P	M3 M3.5 M4 M5	7.7:1	189	228	
NT-150	1.1kW	4P	M3.5 M4 M5	13:1	112	135	
NT-200	1.5kW	4P	M3.5 M4 M5 M6	16:1	92	110	
NT-300	2.2kW	4P	M4 M5 M6	16:1	92	110	
NT-500	3.75kW	4P	M5 M6 M7	16:1	92	110	

End Carriage Spare Parts - Hand Seal Retainer

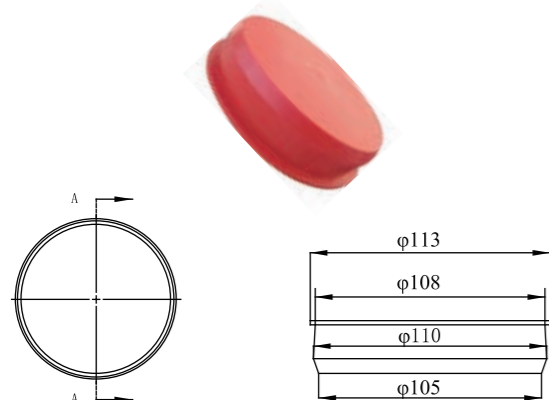

End Carriage Spare Parts - Buffer

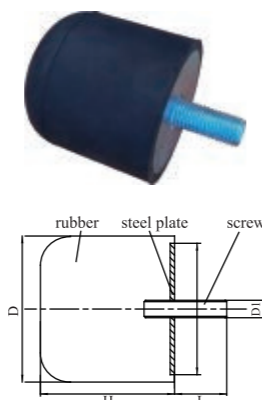

Model	Dimensions (mm)		
	Height×φ	D1	L
B60	50×60	50	M12*25
B80	80×80	70	M12*25
B100	90×100	90	M12*25
B120	100×120	110	M12*25
B160	160×160	150	M12*25
B200	200×200	190	M12*25

Wheel Dia.(mm)	Group classification of Mechanism(FEM)	Applied Rail Head Width(mm)	Crane Travel Speed(m/min)										
			10	12.5	16	20	25	32	40	50	63	80	100
			Permissible Wheel Load (kN) for S45C, GGG70										
110	M1-M4	35	28.31	27.47	26.63	26.91	24.66	23.54	21.86	20.46	19.34	17.66	16.26
		40	32.35	31.39	30.43	30.75	28.19	26.91	24.98	23.38	22.10	20.18	18.58
		45	36.40	35.32	34.23	34.59	31.71	30.27	28.11	26.31	24.86	22.70	20.90
	M5	35	25.28	24.52	23.77	24.02	22.02	21.02	19.52	18.27	17.27	15.77	14.51
		40	28.89	28.03	27.17	27.46	25.17	24.02	22.31	20.88	19.73	18.02	16.59
		45	32.50	31.53	30.57	30.89	28.31	27.03	25.10	23.49	22.20	20.27	18.66
125	M1-M4	35	32.49	31.85	30.58	30.58	28.67	27.71	25.80	24.21	22.61	21.02	19.11
		40	37.13	36.40	34.94	34.94	32.76	31.67	29.48	27.66	25.84	24.02	21.84
		45	41.77	40.95	39.31	39.31	36.86	35.63	33.17	31.12	29.07	27.03	24.57
	M5	35	29.01	28.44	27.30	27.30	25.59	24.74	23.03	21.61	20.19	18.77	17.06
		40	33.15	32.50	31.20	31.20	29.25	28.28	26.33	24.70	23.08	21.45	19.50
		45	37.29	36.56	35.10	35.10	32.91	31.81	29.62	27.79	25.96	24.13	21.94
140	M1-M4	40	41.99	41.18	39.95	39.14	37.51	36.28	34.25	32.21	30.17	28.13	25.68
		45	47.24	46.32	44.95	44.03	42.19	40.82	38.53	36.23	33.94	31.65	28.89
		50	52.49	51.47	49.94	48.92	46.88	45.35	42.81	40.26	37.71	35.16	32.10
	M5	40	37.49	36.76	35.67	34.94	33.49	32.40	30.58	28.76	26.94	25.12	22.93
		45	42.18	41.36	40.13	39.31	37.67	36.45	34.40	32.35	30.30	28.26	25.80
		50	46.87	45.96	44.59	43.68	41.86	40.50	38.22	35.95	33.67	31.40	28.67
160	M1-M4	40	49.39	47.99	46.59	45.66	43.80	42.40	40.54	38.67	36.34	34.01	31.22
		45	55.56	53.99	52.42	51.37	49.27	47.70	45.60	43.51	40.88	38.26	35.12
		50	61.73	59.99	58.24	57.08	54.75	53.00	50.67	48.34	45.43	42.52	39.02
	M5	40	44.10	42.85	41.60	40.77	39.10	37.86	36.19	34.53	32.45	30.37	27.87
		45	49.61	48.20	46.80	45.86	43.99	42.59	40.72	38.84	36.50	34.16	31.36
		50	55.12	53.56	52.00	50.96	48.88	47.32	45.24	43.16	40.56	37.96	34.84
200	M1-M4	45	71.42	69.45	67.49	65.52	63.55	61.59	59.62	57.00	53.73	50.45	47.17
		55	87.29	84.88	82.48	80.08	77.68	75.28	72.87	69.67	65.67	61.66	57.66
		65	103.16	100.32	97.48	94.64	91.80	88.96	86.12	82.34	77.60	72.87	68.14
	M5	45	63.77	62.01	60.26	58.50	56.75	54.99	53.24	50.90	47.97	45.05	42.12
		55	77.94	75.79	73.65	71.50	69.36	67.21	65.07	62.21	58.63	55.06	51.48
		65	92.11	89.57	87.04	84.50	81.97	79.43	76.90	73.52	69.29	65.07	60.84
250	M1-M4	45	90.91	89.27	86.81	84.36	81.90	79.44	76.99	74.53	71.25	67.16	63.06
		55	111.11	109.11	106.11	103.10	100.10	97.10	94.09	91.09	87.09	82.08	77.08
		65	131.31	128.95	125.40	121.85	118.30	114.75	111.20	107.65	102.92	97.01	91.09
	M5	45	81.17	79.71	77.51	75.32	73.13	70.93	68.74	66.54	63.62	59.96	56.31
		55	99.21	97.42	94.74	92.06	89.38	86.69	84.01	81.33	77.76	73.29	68.82
		65	117.24	115.13	111.96	108.79	105.63	102.46	99.29	96.12	91.89	86.61	81.33
320	M1-M4	45	118.46	116.36	114.27	111.12	107.98	104.83	101.69	98.54	95.40	91.20	85.96
		55	144.78	142.22	139.66	135.82	131.97	128.13	124.28	120.44	116.60	111.47	105.06
		65	171.11	168.08	165.05	160.51	155.97	151.42	146.88	142.34	137.80	131.74	124.17
	M5	45	105.77	103.90	102.02	99.22	96.41	93.60	90.79	87.98	85.18	81.43	76.75
		55	129.27	126.98	124.70	121.26	117.83	114.40	110.97	107.54	104.10	99.53	93.81
		65	152.78	150.07	147.37	143.31	139.26	135.20	131.14	127.09	123.03	117.62	110.86
400	M1-M4	55	182.58	180.98	177.78	174.57	169.77	164.96	160.16	155.36	150.55	145.75	137.74
		65	215.78	213.89	210.10	206.32	200.64	194.96	189.28	183.60	177.92	172.24	162.78
		75	248.98	246.79	242.42	238.06	231.50	224.95	218.40	211.85	205.30	198.74	187.82
	M5	55	163.02	161.59	158.73	155.87	151.58	147.29	143.00	138.71	134.42	130.13	122.98
		65	192.66	190.97	187.59	184.21	179.14	174.07	169.00	163.93	158.86	153.79	145.34
		75	222.30	220.35	216.45	212.55	206.70	200.85	195.00	189.15	183.30	177.45	167.70
500	M1-M4	65	272.09	269.72	267.36	262.63	257.89	250.80	243.70	236.60	229.50	222.40	215.31
		75	313.95	311.22	308.49	303.03	297.57	289.38	281.19	273.00	264.81	256.62	248.43
		85	355.81	352.72	349.62	343.43	337.25	327.96	318.68	309.40	300.12	290.84	281.55
	M5	65	242.94	240.83	238.71	234.49	230.26	223.93	217.59	211.25	204.91	198.58	192.24
		75	280.31	277.88	275.44	270.56	265.69	258.38	251.06	243.75	236.44	229.13	221.81
		85	317.69	314.93	312.16	306.64	301.11	292.83	284.54	276.25	267.96	259.68	251.39
630	M1-M4	65	348.80	342.83	339.85	336.87	330.91	324.95	316.00	307.06	298.12	289.17	280.23
		75	402.46	395.58	392.14	388.70	381.82	374.94	364.62	354.30	343.98	333.66	323.34
		85	456.12	448.32	444.42	440.52	432.73	424.93	413.23	401.54	389.84	378.15	366.45
	M5	65	311.42	306.10	303.44	300.78	295.45	290.13	282.15	274.16	266.18	258.19	250.20
		75	359.34	353.19	350.12	347.05	340.91	334.77	325.55	316.34	307.13	297.91	288.70
		85	407.25	400.29	396.81	393.32	386.36	379.40	368.96	358.52	348.08	337.63	327.19

Special Note: NANTE can offer 42Crmo forged steel material for heavy duty crane, and the wheel load is 1.3time more than S45C wheel material under the